

Application Specific Blowers

DR 404/454/505/513/656

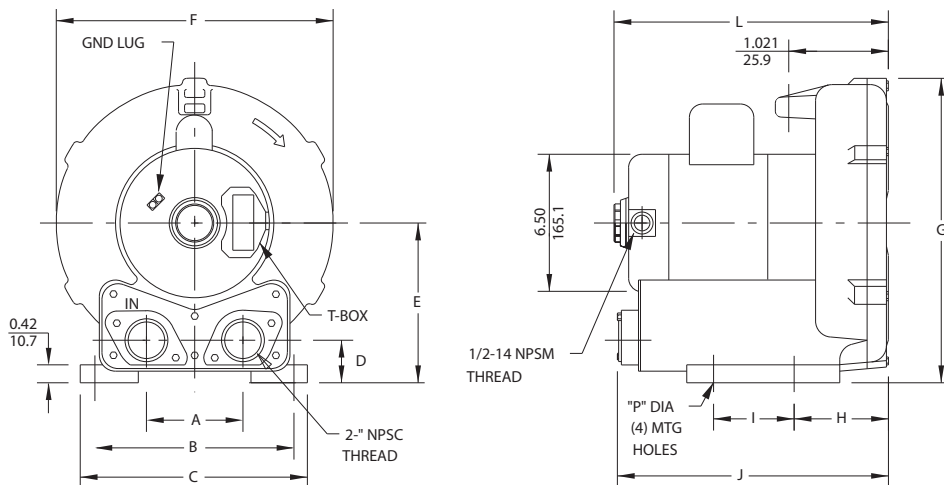

Spa Blowers



IN
MM

- NOTES
 1 DRAWING NOT TO SCALE, CONTACT FACTORY FOR SCALE CAD DRAWING.
 2 CONTACT FACTORY FOR BLOWER MODEL LENGTHS NOT SHOWN.

MODEL	A (IN/MM)	B (IN/MM)	C (IN/MM)	D (IN/MM)	E (IN/MM)	F (IN/MM)	G (IN/MM)	H (IN/MM)	I (IN/MM)	J (IN/MM)	K (IN/MM)	L (IN/MM)
DR404AQ58M	4.75/120.7	8.93/226.8	10.12/257	192/48.8	6.28/159.5	11.5/292.1	12.16/308.9	3.0/76.2	3.75/95.3	12.88/372.2	.59/15	12.91/327.9
DR454V58	4.75/120.7	10.30/261.6	11.38/289.1	1.92/48.8	6.98/177.3	12.55/318.8	13.52/343.4	3.25/82.6	4.50/114.3	10.81/274.6	.59/15	14.45/367
DR505AW58M	4.75/120.7	10.30/261.6	11.70/297.2	1.87/47.5	7.26/184.4	13.53/343.7	14.38/365.3	3.56/92.7	4.50/114.3	14.38/365.3	.59/15	15.0/381
DR513V58	4.75/120.7	11.42/290.1	13.0/330.2	2.23/56.6	8.69/220.7	14.21/360.9	15.8/401.3	3.72/94.5	5.50/139.7	13.74/349	.59/15	14.58/370.3
DR656K58X	4.92/125	11.42/290.1	12.8/325.1	2.25/57.2	7.46/189.5	15.42/391.7	15.17/385.3	4.14/105.2	5.5/139.7	15.12/384.1	.59/15	15.51/393.9

Specification	Units	Part/Model Number				
		DR404AQ58M 037778	DR454V58M 080485	DR505AW58M 037935	DR513V58 038143	DR656K58X 080603
Motor Enclosure - Shaft Mtl.	-	SPA (ODP)-CS	SPA (ODP)-CS	SPA (ODP)-CS	SPA (ODP)-CS	TEFC-CS
Horsepower	-	1.0	1.5	2.0	1.5	3.0
Voltage	AC	115/230	115/230	115/230	115/230	115/230
Phase - Frequency	-	Single-50/60 Hz	Single-50/60 Hz	Single-50/60 Hz	Single-50/60 Hz	Single-50/60 Hz
Insulation Class	-	F	F	F	F	F
NEMA Rated Motor Amps	Amps (A)	15/7.5	15.2/7.6	21/10.5	15.2/7.6	31/15.5
Service Factor	-	1.4	1.3	1.2	1.3	1.0
Maximum Blower Amps	Amps (A)	8/4	17/8.5	26/13	17/8.5	27.8/13.9
Locked Rotor Amps	Amps (A)	32/16	85/43	136/68	85/43	200/100
Recommended NEMA Starter Size	-	0/00	1/0	1/0	1/0	1.5/1
Shipping Weight	Lbs	64	76	83	90	51
	Kg	29	34.5	37.6	40.8	23.1
Recommended Number of Jets	-	3-6	5-10	5-10	12-17	8-12

Voltage - ROTRON motors are designed to handle a broad range of world voltages and power supply variations. Our dual voltage 1 phase motors are factory tested and certified to operate on both: **104-115/208-230 VAC-1 ph-60 Hz** and **100-110/200-220 VAC-1 ph-50 Hz**. All voltages above can handle a ±10% voltage fluctuation. Special wound motors can be ordered for voltages outside our certified range.

Operating Temperatures - Maximum operating temperature: Motor winding temperature (winding rise plus ambient) should not exceed 140°C for Class F rated motors or 120°C for Class B rated motors. Blower outlet air temperature should not exceed 140°C (air temperature rise plus inlet temperature). Performance curve maximum pressure and suction points are based on a 40°C inlet and ambient temperature. Consult factory for inlet or ambient temperatures above 40°C.

Maximum Blower Amps - Corresponds to the performance point at which the motor or blower temperature rise with a 40°C inlet and/or ambient temperature reaches the maximum operating temperature.

- Notes**
 - The blower should not be stopped/started more than four times an hour.
 - Use of relief valve 515092 is required for all blowers.

This document is for informational purposes only and should not be considered as a binding description of the products or their performance in all applications. The performance data on this page depicts typical performance under controlled laboratory conditions. AMETEK is not responsible for blowers driven beyond factory specified speed, temperature, pressure, flow or without proper alignment. Actual performance will vary depending on the operating environment and application. AMETEK products are not designed for and should not be used in medical life support applications. AMETEK reserves the right to revise its products without notification. The above characteristics represent standard products. For product designed to meet specific applications, contact AMETEK Technical & Industrial Products Sales department.

Application Specific Blowers

DR 404/454/505/513/656

Spa Blowers

FEATURES

- Manufactured in the USA - ISO 9001 and NAFTA compliant
- CE compliant - Declaration of Conformity on file
- Maximum flow: 105, 127, 160, 200 or 78 SCFM
- Maximum pressure: 56, 58, 74, 69 or 88 IWG
- Standard motor: 1.0, 1.5, 2.0, 3.0 HP, Spa Duty ODP
- Cast aluminum blower housing, impeller & cover; cast iron flanges (threaded)
- UL & CSA approved motor with permanently sealed ball bearings and Class B rated thermal protection
- Inlet & outlet internal muffling
- Quiet operation within OSHA standards

MOTOR OPTIONS

- International voltage & frequency (Hz)
- Chemical duty, high efficiency, inverter duty or industry-specific designs
- Various horsepower for application-specific needs

BLOWER OPTIONS

- Corrosion resistant surface treatments & sealing options
- Remote drive (motorless) models
- Slip-on or face flanges for application-specific needs

ACCESSORIES

- Flowmeters reading in SCFM
- Filters & moisture separators
- Pressure gauges, vacuum gauges, & relief valves
- Switches - air flow, pressure, vacuum, or temperature
- External mufflers for additional silencing
- Variable frequency drive package



ROTRON®

Blower Performance at Standard Conditions

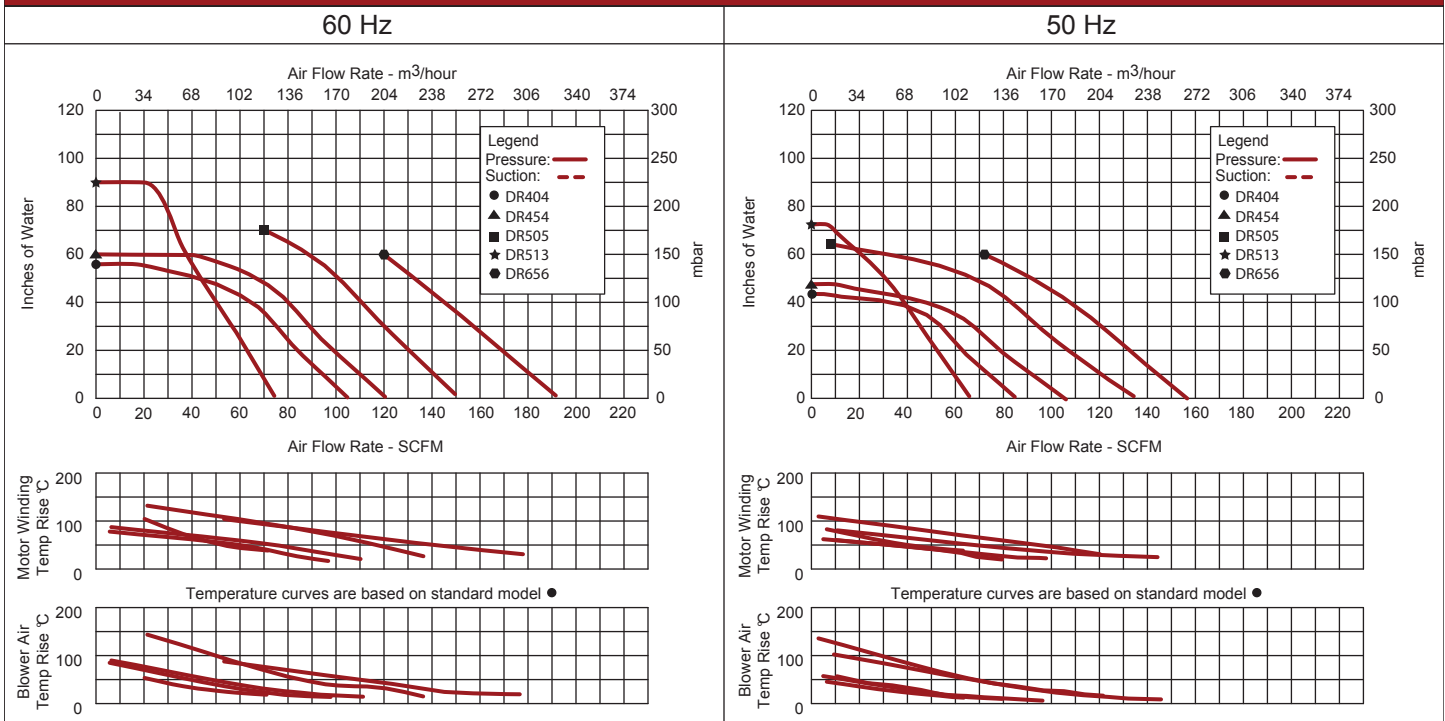

This document is for informational purposes only and should not be considered as a binding description of the products or their performance in all applications. The performance data on this page depicts typical performance under controlled laboratory conditions. AMETEK is not responsible for blowers driven beyond factory specified speed, temperature, pressure, flow or without proper alignment. Actual performance will vary depending on the operating environment and application. AMETEK products are not designed for and should not be used in medical life support applications. AMETEK reserves the right to revise its products without notification. The above characteristics represent standard products. For product designed to meet specific applications, contact AMETEK Technical & Industrial Products Sales department.

AMETEK DYNAMIC FLUID SOLUTIONS
 75 North Street, Saugerties, NY 12477
 USA: +1 215-256-6601 - Europe: +49 7703 930909 - Asia: +86 21 5763 1258
 Customer Service Fax: +1 215.256.1338
 www.ametekdfs.com