

8" ROUND STAR ANTI-ENTRAPMENT SUCTION OUTLET COVER, SOLID RISER RING AND MUD FRAME

VGB Series

The AquaStar line of suction outlet covers, compliant with the Virginia Graeme-Baker Pool and Spa Safety Act (ANSI/APSP 16-2011 and NSF/ANSI 50-2009a)

FEATURES

For single or multiple drain use
No sump required
(see installation instructions)

Single –

Floor: 140 GPM at 2.8 fps

Wall: 84 GPM at 1.7 fps

16.0 square inch opening

Additional sump versions also available

Trademarked VGB compliance button easily identifies VGB 2008 compliant cover from on deck and underwater

#316 stainless steel screws

Manufactured from superior UV-resistant engineered polymers

Meets or exceeds ANSI/APSP 16-2011 and NSF/ANSI 50-2009a national standards and ASTM G154 UV testing

Replace drain cover every five years from the date of installation

24 per case

U.S. patent D621009

No sump required!



Part # A8Rxxx

Fits: AquaStar (all standard 8" models), American, Pentair, Color Match, Waterway and most Custom Molded (CMP)

STANDARD COLORS

- A8R101 – White
- A8R102 – Black
- A8R103 – Light Gray
- A8R104 – Blue
- A8R105 – Dark Gray
- A8R108 – Tan

Also available as frame only
p/n 8FRxxx
24 per case

VGB 2008 Compliant

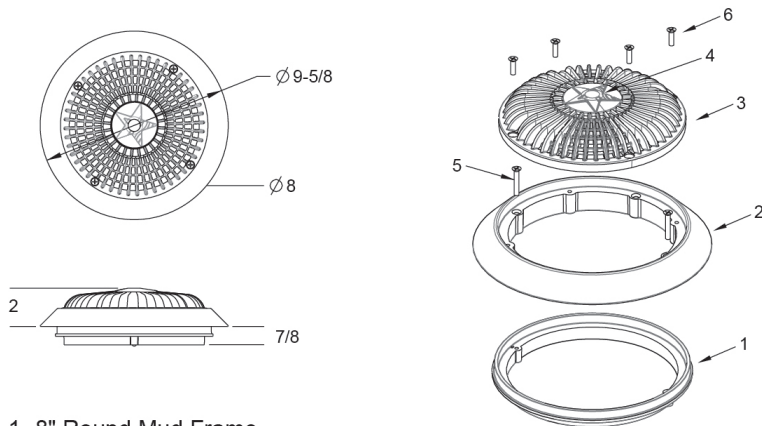

1. 8" Round Mud Frame
2. 8" Round Riser Ring
3. 8" Round Anti-Entrapment Cover
4. VGB Compliance Button
5. 10 x 1-1/4" Flat-Head Phillips, 316 SS, Qty 2
6. 10 x 3/4" Flat-Head Phillips, 316 SS, Qty 4