

# SPA LIFT ELITE (68)



## Item# F-006SLE

The Spa Lift Elite is a fully powered ADA compliant lift designed especially to provide access to elevated pools and spas. Pair it up with a swim spa and enjoy the benefits of aquatic exercise, improved health, and increased independence. The Elite offers easy push button controls and 360 degrees of rotation.

The Spa Lift Elite is constructed of quality stainless steel and coated with a durable powder coat finish. Whether relaxation, rehabilitation, or socialization is your goal, the Spa Lift Elite is the solution to stress-free access to your personal backyard or commercial spa.



### FEATURES:

- UL Certified
- 300 lb (136 kg) weight capacity
- Clearances vary by wall height & width
- Wall height range 21" - 68" (54 - 172 cm)
- 360 degree powered rotation in either direction
- Adjustable pull-out leg rest
- Flip-up armrests
- Five year structural warranty
- Five year pro-rated electronics warranty

### ACCENT COLORS

Available in a variety of accent and powder coat colors



\*Blue seat standard (not a powder coat option)

### OPTIONS/ACCESSORIES:

F-SPAACK8	Anchor, standard tri-point anchor system
F-107UEWDA	Anchor, wood deck applications
F-450SLECS	Cover, standard lockable, blue
F-450SLECS-T	Cover, standard lockable, tan
F-450SLECS-G	Cover, standard lockable, gray
F-422PLH-2	Headrest
F-042SCH	Solar charging station

### PROUDLY SOLD BY:

SPA LIFT SERIES

# THE SPA LIFT ELITE

## PRODUCT SPECIFICATIONS

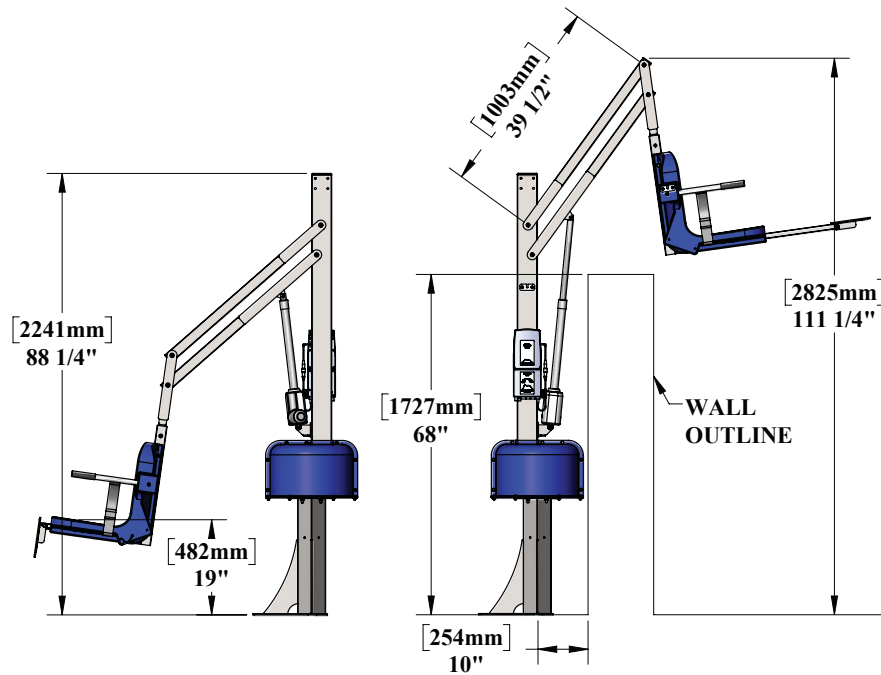

## APPLICABLE POOL PROFILES

### RAISED POOL / SPA

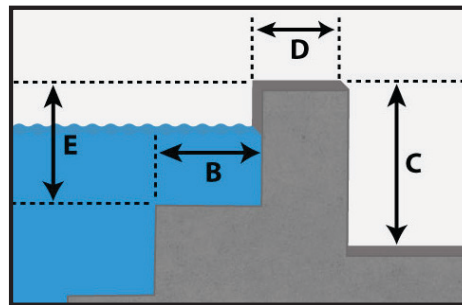

To confirm specific application go to [www.aquacreek.com](http://www.aquacreek.com) for our Pool Lift Selector  
Become a member of our new Dealer and Architect page. Access to CAD blocks,  
CSI specs and sales materials.