



Product Manual

VaporMan 125[®] Manifold Vaporizer System



Designed and Built by:

Chart Inc.

***407 7th Street NW
New Prague, MN 56071 USA
(800) 400-4683***



Contents

Revision Log	iv
Preface	1
General	1
Product Highlights.	1
Common Installations	1
Product Manual	1
Terms	2
Acronyms / Abbreviations.	2
Safety	3
General	3
Handling the VaporMan 125® Unit	3
Inhalation of CO ₂ Gas	4
Contact with Dry Ice	4
Spill or Leak Procedures	4
Disconnecting Precautions	4
CO ₂ Monitoring Systems	4
First Aid and Emergency Action	4
Introduction	5
General	5
System Overview	5
Physical Description.	5
VaporMan 125® Components.	5
Vaporizing Circuit	5
Safety Pressure Relief Section	5
Tank Connections.	5
Option Kits	6
High Flow Regulator	6
Operations.	7
Initial Inspections	7
Filling Procedures	7
Installing the VaporMan 125® Unit	7
Plumbing Procedures	8
Carbo-Max® 1000 Bulk CO ₂ System Parts to be Added	8
Carbo-Max 1000 Bulk CO ₂ System Parts to be Removed	8
Carbo-Max® 750 Bulk CO ₂ System Parts to be Added.	9
Carbo-Max 750 Bulk CO ₂ System Parts to be Removed.	9
Connecting to the VaporMan 125 Unit	10
Delivering CO ₂ to the VaporMan 125 System.	10
Maintenance & Troubleshooting.	11
Replacing the Economizing Regulator	11
Miscellaneous Fittings.	11
Troubleshooting	11
Specifications	13
General Arrangement and Flow Schematics	13
VaporMan 125® Single Unit	13
VaporMan 125 Unit with Carbo-Max® 750 Bulk CO ₂ System	14
VaporMan 125 Unit with Carbo-Max® 1000 Bulk CO ₂ System	15
VaporMan 125 Unit with Perma-Cyl® MicroBulk Storage System	16

Set-up and Dimensions 18
 VaporMan 125® Unit 18
 VaporMan 125 Unit with Carbo-Max® 750 Bulk CO₂ System 19
 VaporMan 125 Unit with Carbo-Max® 1000 Bulk CO₂ System 19
 VaporMan 125 Unit with Perma-Cyl® MicroBulk Storage System 20

Warranty 21
 Warranty Policy 21
 Warranty Claims Procedure 22

Revision Log

Revision Level	Date	Description
A	02/18/2014	Original
B	01/29/2018	Reformat



Preface

General

The VaporMan 125 Manifold Vaporizer System is a CO₂ vaporizer and manifold combination intended for use with the Carbo-Max® Bulk CO₂ System tanks and CO₂ configured Perma-Cyl® MicroBulk Storage System tanks. The VaporMan 125 system consists of one 2-fin parallel style vaporizer and one 2-fin series style vaporizer connected together. The unit also includes a manifold for connecting a single tank or multiple tanks in pairs. The vaporizers and manifold are mounted to a stainless steel pedestal which is attached to a 27" x 27" x 3/8" stainless steel base plate.

Product Highlights

- Compact design, less than 2-1/2 feet square and 4 feet tall
- Cost effective compared to larger traditional ambient vaporizers
- Easy to attach to bulk CO₂ tanks using the manifold connections

Common Installations

- Micro-Breweries
- Large water parks for pH control
- Large sports arenas such as professional and college football stadiums

Product Manual

The VaporMan 125 Manifold Vaporizer System Product Manual is designed to be used in conjunction with all VaporMan 125 models and kits provided by Chart. This manual contains information regarding the safe operation and handling of liquid carbon dioxide with the cylinder and the vaporizer manifold system. It should be thoroughly read and understood by anyone that operates, or is exposed to this equipment. If there are any questions regarding the operation of the VaporMan 125 System, contact Chart's Technical Service division at 1-800-400-4683.

The safety requirements for operating the vaporizer manifold including the handling and transporting of extremely cold liquid products are shown in the Safety section. It is imperative that all persons having contact with the VaporMan 125 Manifold system become thoroughly familiar with all maintenance, safety precautions, and procedures contained in this product manual.

The Introduction section discusses the general features of the VaporMan 125 system and the theory of operation.

The Operations section gives step-by-step procedures for the basic operation of the VaporMan 125 system and the tanks involved.

The Maintenance & Troubleshooting section will become an invaluable tool for answering various possible questions that may arise while using the VaporMan 125 system.

Please refer to the Specifications section for schematics, flow diagrams, part numbers and set-up dimensions.

Terms

Throughout this manual safety precautions will be designated as follows:



Warning! *Description of a condition that can result in personal injury or death.*



Caution! *Description of a condition that can result in equipment or component damage.*



Note: *A statement that contains information that is important enough to emphasize or repeat.*

Acronyms / Abbreviations

The following acronyms / abbreviations are used throughout this manual:

CO ₂	Carbon Dioxide
MAWP	Maximum Allowable Working Pressure
ODT	Outer Dimension Tube
PB	Pressure Builder
PN	Part Number
PSI	Pounds per Square Inch
PSIG	Pounds per Square Inch (Gauge)
RV	Relief Valve



Safety

General

While Chart equipment is designed and built to the most rigid standards, no piece of mechanical equipment can ever be made 100% foolproof. Strict compliance with proper safety and handling practices are necessary when using a cryogenic manifold device or other compressed gas equipment. We recommend that all of our customers re-emphasize safety and safe handling practices to all their employees and customers. While every possible safety feature has been designed into the VaporMan 125 manifold system and safe operations are anticipated, it is essential that the customer carefully read and fully understand all **WARNING** and **CAUTION** notes listed in this safety summary and enumerated below.



Warning! *CO₂ gas is a colorless, odorless, tasteless gas that displaces oxygen and does not support life. The gas is difficult to detect without assistance of special equipment. Avoid breathing or contacting CO₂ in gas, liquid or solid form.*

Exposure to concentrations of more than 3% in air can cause physical symptoms including unconsciousness, serious injuries or death. Even low concentrations of CO₂ can cause:

- Dizziness, headaches, nausea or disorientation
- Increased respiration or heart rate
- Shortness of breath or rapid suffocation

CO₂ is heavier than air and can collect in low areas such as basements, stairwells, and confined spaces. Avoid entry into areas where CO₂ leaks or high concentrations of CO₂ are suspected. Enter those areas with caution only after they have been thoroughly ventilated.

Handle liquid so that it will not splash or spill. Protect your eyes and cover skin where the possibility of contact with liquid CO₂, cold pipes and equipment, or cold gas exists. Safety goggles or a face shield should be worn at all times when connecting to fill connections, while filling the tank and during disconnection from the fill connection. Clean, insulated gloves that can be easily removed and long sleeves are recommended for arm and hand protection. Cuffless trousers should be worn over the shoes to shed spilled liquid.



Warning! *Before removing cylinder parts or fittings, completely empty the liquid cylinder of liquid and release the entire vapor pressure in a safe manner. External valves and fittings can become extremely cold and may cause painful burns to personnel unless properly protected. Personnel must wear protective gloves and eye protection whenever removing parts or loosening fittings. Failure to do so may result in personal injury because of extreme cold and pressure in the cylinder.*



Caution! *Use only replacement equipment, which is compatible with carbon dioxide and has been cleaned for oxygen use. Do not use regulators, fittings, hoses, etc., which have been previously used in a compressed air environment. Similarly, do not use oxygen equipment for compressed air. Failure to comply with these instructions may result in serious damage to the liquid cylinder.*



Caution! *The VaporMan 125 unit must be secured to the floor. Failure to comply with this procedure may result in damage to the unit.*

Handling the VaporMan 125 Unit

The VaporMan 125 unit is shipped on a pallet. The preferred handling method is a forklift that lifts the pallet and places it. However, the permanent placement of the VaporMan 125 unit can be done by hand. The unit comes with four holes in the base plate in order to secure it to the floor. The VaporMan125 unit is rather light and can be moved by two people with ease. Be careful when moving the unit as the vaporizer fins can be sharp.

Inhalation of CO₂ Gas

If exposed to CO₂ gas remove yourself or the individual to fresh air immediately. If the subject is not breathing provide a means of artificial respiration. If there is difficulty breathing, an oxygen supply will be beneficial. Call a physician or paramedics for help.

Contact with Dry Ice

If exposed to dry ice, stop exposure at once. Do not pour water on wound. Seek immediate medical attention.

Spill or Leak Procedures

In the event of a CO₂ leak or spill, evacuate all personnel from the affected area. Ventilate the exposed area thoroughly before re-entering. Do not forget to ventilate any low areas such as a basement or stairwells that may have collected carbon dioxide.

Disconnecting Precautions

Always wear gloves and protective eye wear when disconnecting liquid CO₂ fittings and hoses. After using the VaporMan 125 system make sure all of the valves supplying the system are closed. Slowly remove the connection fittings and hoses to relieve pressure from the lines and the VaporMan 125 unit.

CO₂ Monitoring Systems

The Analox 50™ and Ax 50™ Carbon Dioxide Analyzers are precision instruments that provide continuous, accurate monitoring of CO₂ levels to ensure a safe working environment for your employees, suppliers and yourself.

A proven system with over 80,000 units installed worldwide. The Chart/Analox 50 Monitoring System is comprised of one detector (with visual and audible alarms) and one alarm repeater for remote mounting. The Chart/Ax 50 Monitoring System includes one detector, one alarm repeater and one relay for additional notifications.

For more information look for PN 13586611 on <http://literature.chart-ind.com>.

First Aid and Emergency Action

If inhaled:

- Move to fresh air immediately
- If not breathing, give artificial respiration
- If breathing is difficult, give oxygen
- Get immediate medical attention

In case of frostbite:

- End exposure immediately
- Do not rub or pour water on the affected area
- Get immediate medical attention

Rescue:

- Do not attempt a rescue in areas of high CO₂ concentrations without proper self contained breathing apparatus.
- Thoroughly ventilate areas of possible high CO₂ concentration before entering.

In case of spills or leaks:

- Evacuate all personnel immediately from affected areas
- Thoroughly ventilate the area of the spill or leak before entering

Introduction

General

The VaporMan125 Manifold Vaporizer System is designed to combine two bulk carbon dioxide tanks or one carbon dioxide Perma-Cyl® MicroBulk Storage System tank on a reliable, economical basis. The unit is intended to fulfill the high flow requirements of distributors for micro-breweries, stadium applications, industrial applications, and various other high-flow applications.

The VaporMan 125 system comes with all the necessary fittings to connect two Carbo-Max® 750 Bulk CO₂ System tanks to the unit. A separate kit can be bought along with the VaporMan 125 system for two Carbo-Max 1000 tanks. There is also a specific part number for a VaporMan 125 system Perma-Cyl tank.

System Overview

The VaporMan 125 system consists of two vaporizers, one parallel and one series, and a manifolding sub-assembly. The CO₂ enters the manifolding section and is combined before being routed to the parallel vaporizer. The parallel vaporizer vaporizes the CO₂ into cold gas. The cold gas then enters the series vaporizer, which warms the cold gas to an adequate temperature before being sent downstream to equipment.

The design and construction of the VaporMan 125 system is aimed at building the most efficient and affordable vaporizing unit available. Engineered as a complete high flow vaporizing system, the VaporMan 125 system can be coupled with a high flow regulator to achieve flow rates of 125 lbs/hour (56 kg/hr). The manifolding section of the VaporMan 125 system makes installation simple and straight forward. The unit is essentially a plug and play assembly.

The vaporizers are connected in a specific order and the vaporizer selection was intentional. The parallel vaporizer is used to vaporize the liquid into cold gas. The gas is then sent through the series vaporizer in order to warm the gas and prepare it to be used downstream.

The VaporMan 125 system is protected from over-pressurization by a primary safety relief valve set at 350 psig. This has been included for the time when the system may be mistakenly isolated or if a blockage occurs.

Physical Description

VaporMan 125 Components

The components on the manifold section can be used in three ways:

- Two Carbo-Max 750 or 1000 tanks
- One Carbo-Max 750 or 1000 tank
- One Perma-Cyl tank

The manifold section provides four connections, a pressure gauge and an economizer regulator. The manifold section is mounted to a panel that is conveniently located for ease of hook up. The connections are standard 5/8" ODT 45° flare. This is the fitting needed for the standard fill hoses that are used on all beverage tank installations.

Vaporizing Circuit

The vaporizing circuit includes two vaporizers. One vaporizer is a parallel ambient vaporizer and the other is a series ambient vaporizer. The vaporizers are connected in order to maximize the vaporization of the product. The parallel vaporizer is used to quickly vaporize liquid into gas. The series vaporizer is used to warm the gas, not vaporize liquid. Each of the vaporizers has a 600 psi maximum allowable working pressure.

Safety Pressure Relief Section

The safety relief is a 350 psi pressure relief device. This is to relieve pressure in the event liquid were to be trapped in the vaporizers or in case of fire.

*Each VaporMan 125 PED model is equipped with relief devices with set pressures of 20.68 Bar.

Tank Connections

Multiple fittings and components are included with the VaporMan 125 kit. All the necessary hoses, check valves, caps, and connections are included for two Carbo-Max 750 tanks. The check valves included ensure that no water or foreign product compromises the carbon dioxide tanks. The bushings and connectors are required for making the right connections between the tank and the VaporMan 125 system.

Option Kits

For those who have one or two Carbo-Max® 1000 Bulk CO₂ System tanks or who have one Perma-Cyl® MicroBulk Storage System tank there are two optional kits that will need to be purchased as well. The kit names are 'KIT CARBOMAX VAPORMAN 1000' and 'KIT VAPORMAN 125 PERMA'. Each of these kits includes the hoses and fittings needed in order to use the VaporMan 125 system.

High Flow Regulator

The VaporMan 125 system is designed for high flow applications. The final line regulator that is installed on the beverage tanks can be used at flow rates up to 75 lbs/hour (34 Kg/Hr). If a higher flow rate is desired — i.e. 80 lbs/hour, (36 Kg/Hr), 100 lbs/hour (45 Kg/Hr) or 125 lbs/hour (56 Kg/Hr) — the high-flow regulator can be purchased from www.chartparts.com using part number 11779806.



Operations

Initial Inspections

When the tanks and/or VaporMan 125 system are first received they should be inspected for shipping damage. Never fill a damaged tank or use a damaged VaporMan 125 system.

If the tanks arrive with zero pressure, they should be pressurized and checked for leaks.

Filling Procedures

Before filling the tank it should be visually inspected for possible damage or unsuitability for intended use. If damage is detected (i.e. serious dents, loose fittings, etc.) remove the unit from service and conduct the necessary repairs as soon as possible.

It is recommended that when using two Carbo-Max® 750 or 1000 Bulk CO₂ System tanks that you install two fill boxes. This will help in confirming that both tanks are completely full. If there are no fill boxes, then you can fill the tanks individually. When there are no fill boxes, please make sure you have an adequate way to pipe the vent circuits outdoors in a safe manner.

Installing the VaporMan 125 Unit

The VaporMan 125 unit is assembled with a stand and base. The base has a hole in each corner. This will serve as the location for the bolts that will be used to anchor the unit to the floor. The VaporMan 125 unit should be anchored to the floor in an accessible location and conveniently located for easy connections. A place that has circulation is recommended to aid in melting the ice that might build up on the vaporizers during operation. The VaporMan 125 unit will then need to be connected to the tank or tanks in order to be used.



Note: A video presentation of the installation and instructions for the VaporMan 125 system can be found online at <https://www.youtube.com/user/chartindustries>.

First, there are some parts that must be removed from the two tanks that will be used. Detail drawings of the parts that are to be removed and the parts to be added are included on the next pages of this manual. The Gas Use and Economizer sections will change on the Carbo-Max 750 Bulk CO₂ System, and the Gas Use, Economizer, and Pressure Building sections will change on the Carbo-Max 1000 Bulk CO₂ System. The parts that are removed may be kept and used in other locations if they are in good condition. Some of the parts to be removed will actually be reused when adding the necessary fittings to connect to the VaporMan 125 unit.



Caution! *Make sure to plumb the tanks as we recommend in the following **Plumbing Procedures** section. Do not use any other methods. The plumbing configuration and specific fittings have been tested and proven to work properly. Other methods of plumbing or connecting to the VaporMan 125 system must be cleared through Chart before continuing. Chart is not responsible for improperly plumbed tanks or improperly connected VaporMan 125 units. This could lead to issues with the system, damage or poor performance.*

Plumbing Procedures

As shown in the following illustrations, you will remove the Economizing sections, Gas Use sections and the Pressure Building sections. The parts to be reused are shown on top as well as the parts to be added.

Carbo-Max® 1000 Bulk CO₂ System Parts to be Added

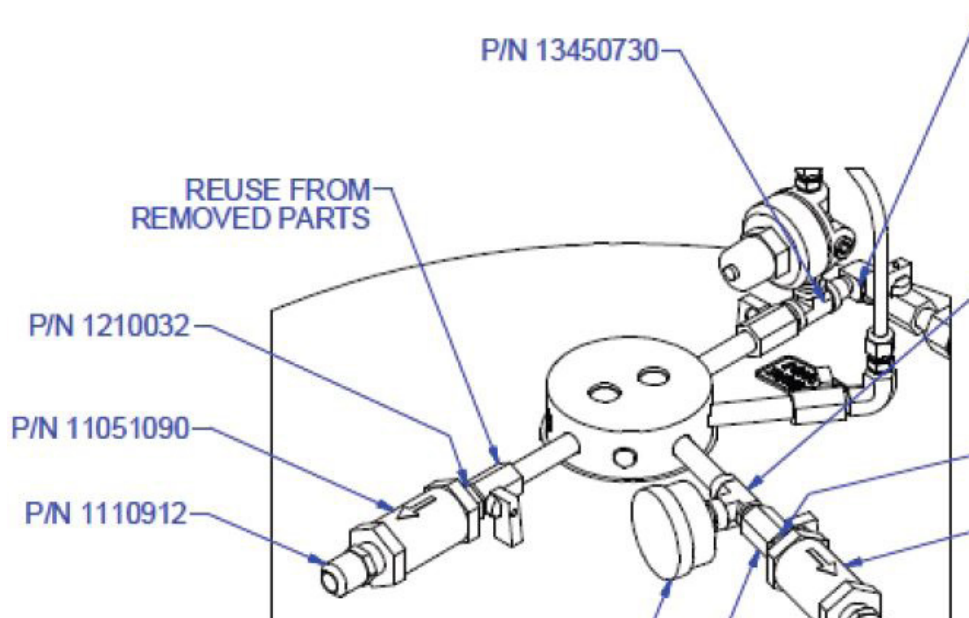

Carbo-Max 1000 Bulk CO₂ System Parts to be Removed

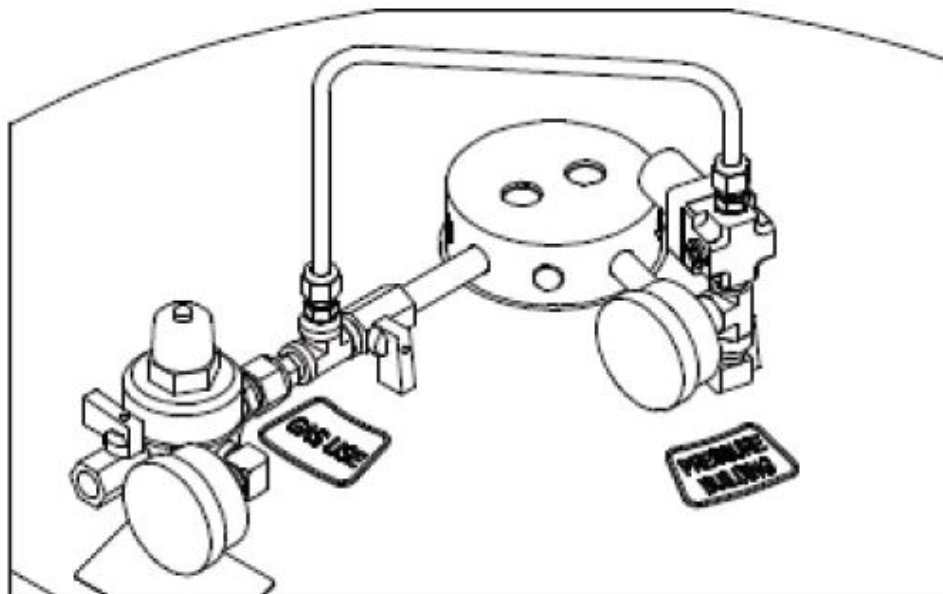

Carbo-Max[®] 750 Bulk CO₂ System Parts to be Added

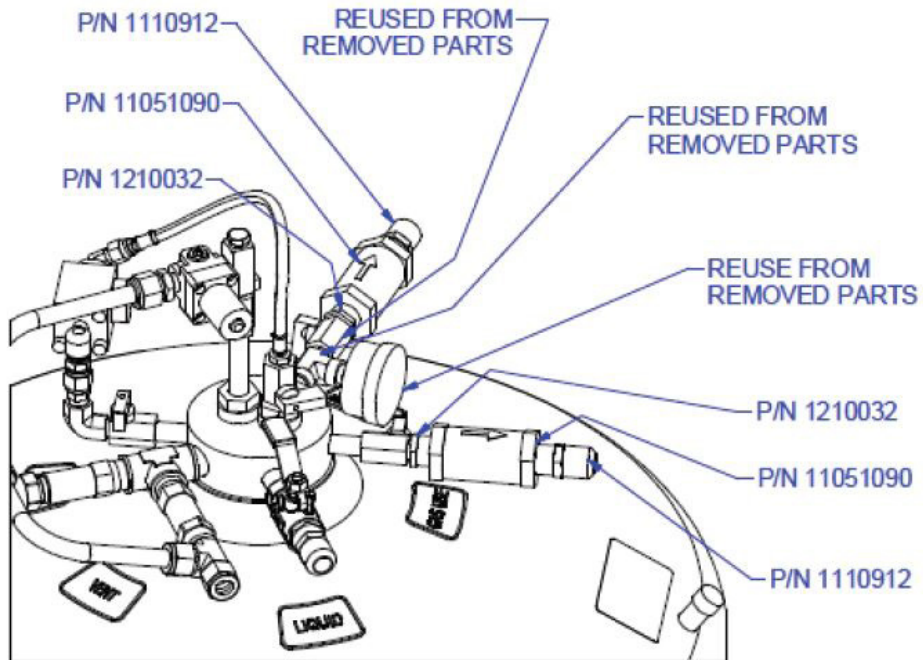

Carbo-Max 750 Bulk CO₂ System Parts to be Removed

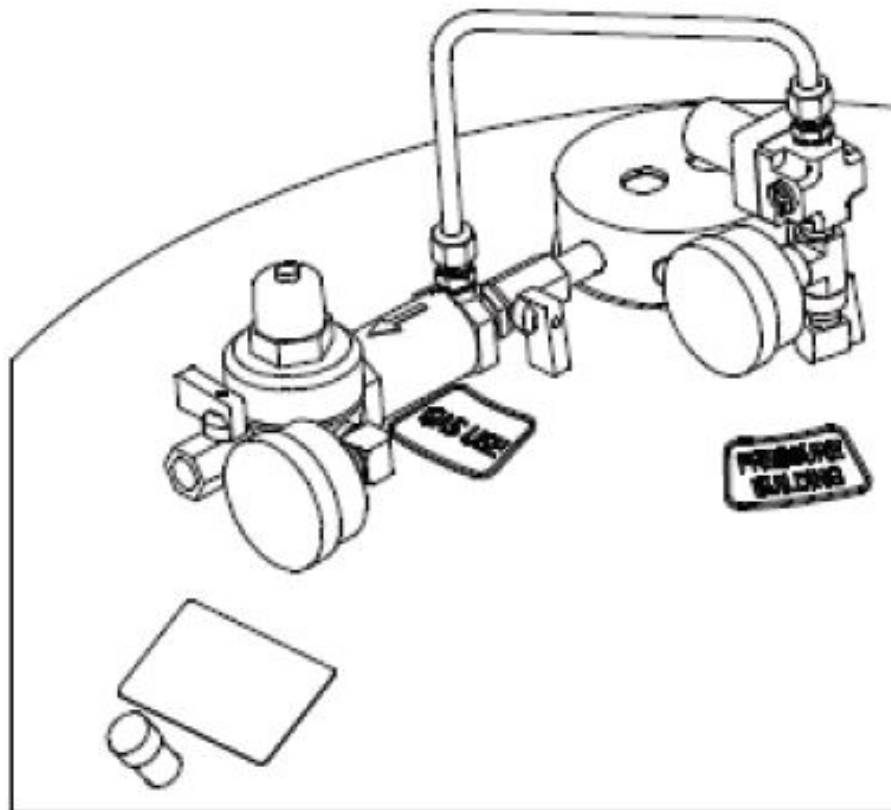

Connecting to the VaporMan 125 Unit

The VaporMan 125 unit is shipped with caps on the four ports on the manifold. If you are using two tanks, you will need to remove all four caps. If you are only using one tank, only remove the left two caps or the two right caps. The transfer hoses that come with the unit can now be connected to their proper ports. The diagrams in the Specifications section of this manual tell which connections match between the VaporMan 125 unit and the tanks. The economizing connections on the tanks should be connected to the two top ports on the VaporMan 125 unit. Each of these connections are 5/8" flared fittings that will mate to the transfer hoses. The gas use connections on the tanks should be routed to the bottom two connections on the manifold. Tighten each end of each hose with a wrench. Check for leaks before pressurizing the system.

For a Carbo-Max® 1000 Bulk CO₂ System the pressure building circuits must be connected. This allows the tanks to equalize their head spaces. This is an integral part in the success of this set-up. If the head spaces are not connected the tanks may not distribute CO₂ to the VaporMan 125 unit equally.

The check valves are in place to prevent any back flow into each tank. The check valves also ensure that the tanks equalize and feed the VaporMan 125 system equally.

Delivering CO₂ to the VaporMan 125 System

Once the connections are tightened and the entire unit has been leak checked, the VaporMan 125 system can now be used. A regulator should be placed on the downstream side of the VaporMan 125 unit to reach the desired delivery pressure to your particular application. The regulator can be connected to the VaporMan 125 unit or placed further downstream to take advantage of more vaporization. The final line regulator from one of the tanks may be used, or the high flow regulator PN 11779806 can be ordered from Chart Parts.

The VaporMan 125 system has no isolation valves, therefore the system is operated by opening all of the isolation valves on each tank. The economizing circuit, gas use circuit, and the pressure building circuit (for Carbo-Max 1000 tank) should all be opened on each tank. The VaporMan 125 unit will function as an extension of the tanks and will provide vaporized CO₂ for your application.



Caution! *Once the isolation valves on the tank have been opened pressure should be allowed to escape from the transfer hoses before they are completely removed.*

Maintenance & Troubleshooting

Replacing the Economizing Regulator

The regulator used on the manifold is the same type and part number used in the economizing circuit for the tanks. If the regulator is failing, please replace it with the same regulator.

Miscellaneous Fittings

The remaining pieces on the VaporMan 125 system should be inspected for corrosion or fatigue failure over time. All of the various parts can be provided through www.chartparts.com. The other components of the unit are stainless steel or aluminum and should have great longevity.

Troubleshooting

The following table is arranged in a Trouble/Possible Cause/Remedy format. The possible causes for specific problems are listed in descending order of significance. That is, check out the first cause listed before proceeding to the next. Perform all procedures in order listed and exactly as stated (Refer to drawings as required to locate system components identified in the troubleshooting guide.)

Trouble	Possible Cause	Remedy
VaporMan 125 system pressure is too low or does not build pressure at a sufficient rate	VaporMan 125 unit or system is leaking	If the pressure does not build and stays at a setting lower than desired, check the VaporMan 125 unit or downstream for leaks
	Energy level of liquid in tank is low	The pressure building rate for product stored at a lower pressure will be slower than a product stored at a higher pressure. To achieve best results, maintain the tank pressure at a working pressure above 125 psi.
	Pressure building regulator is set improperly or leaks	If the pressure builds and stays at a pressure higher than desired, adjust the pressure building regulator to a new setting
	Cylinder is leaking	Check for frost on lines or on top of head. Listen for hissing, soap test joints for leaks. Isolate leak and call Chart for repair details
	Vacuum is deteriorating	This can be accompanied by cold or frost occurring evenly over the cylinder surface. Refer to the troubleshooting section on frost
	VaporMan 125 unit has blockage	Check the unit for signs of blockages. Dry ice or foreign material can prevent flow through the unit.
Frost occurs on vaporizers	Vaporizers are working properly	This is normal. Ice may remain for the entirety of the use.

Specifications

General Arrangement and Flow Schematics

VaporMan 125 Single Unit

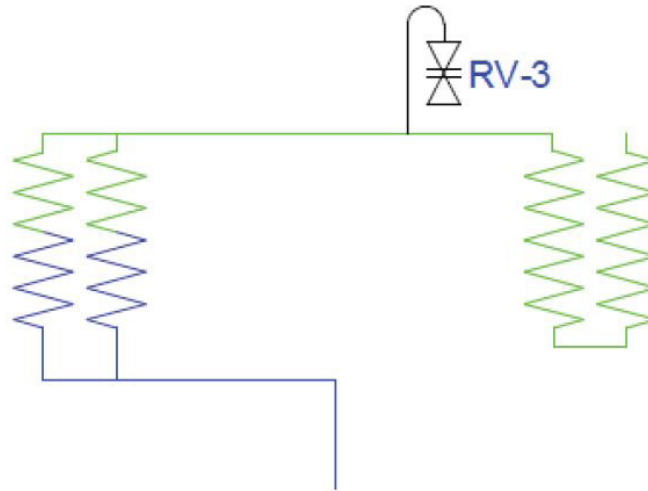

<i>Nomenclature</i>		
<i>Designation</i>	<i>Description</i>	<i>Function</i>
PG-1	PG 2" DIAL 0-400 PSI 1/4" MPT CBM PN 13321014	PRESSURE GAUGE, TANK PRESSURE, ECON PRESSURE
R-1	REGULATOR, 250 NPT @ 150 PSI ECON PN 13154842	ECONOMIZER REGULATOR
RV-2	RV BRS 1/2MPT 450 PSI PN 11708451	VAPORIZER RELIEF VALVE

*PED model equipped with two RVs — 20.68 bar PN 20986538 each

VaporMan 125 Unit with Carbo-Max® 750 Bulk CO₂ System

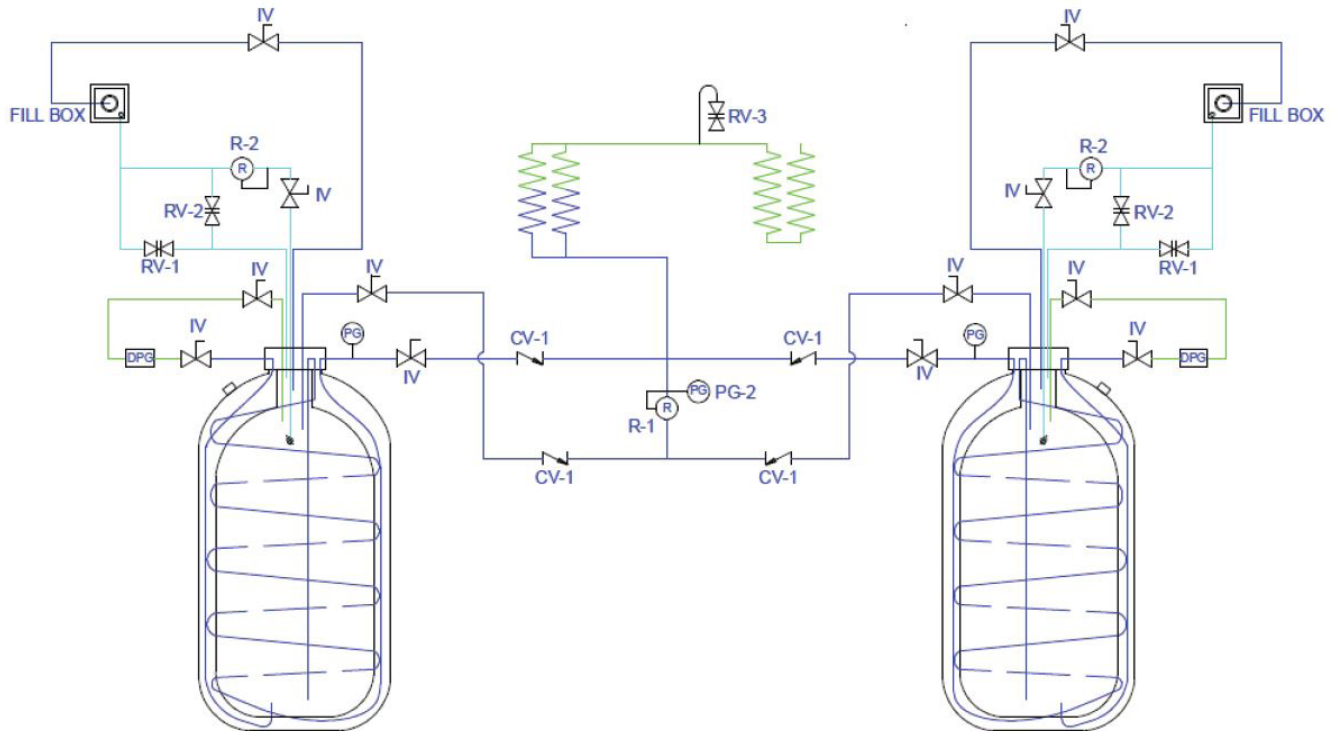

Nomenclature		
Designation	Description	Function
CV-1	VALVE CHECK BRS 1/2FPT*1/2FPT PN 13620233	CHECK VALVE, PRESENT BACK FLOW
PG-2	PG 2" DIAL 0-600 PSI 1/4" MPT CBM PN 11940305	PRESSURE GAUGE, PRESSURE AT ECONOMIZER
R-1	REGULATOR 250 NPT @ 150 PSI ECON PN 13154842	ECONOMIZER REGULATOR
R-2	REGULATOR 250 NPT @ 200 PSI SF PN 13154834	SURE FILL REGULATOR
RV-1	RV BRS 1/2MPT 300 PSI PN 11708400	PRIMARY SAFETY RELIEF VALVE
RV-2	RV BRS 1/2MPT 450 PSI PN 11708451	SECONDARY SAFETY RELIEF VALVE
RV-3	RV BRS 1/4MPT 450 PSI GENERANT PN 11193055	VAPORIZER RELIEF VALVE
DPG	DIFF PG 0-50" 1/8"FPT FULL PN 15096551	DIFF PG TANK LEVEL GAUGE
IV	VALVE ISOLATION BRS ABCO PN 20733160	ISOLATION VALVE
PG-1	PG 2" DIAL 0-400 PSI 1/4" MPT CBM PN 13321014	PRESSURE GAUGE TANK PRESSURE

*PED model equipped with two relief valves (PN 20986538) 20.68 bar each

VaporMan 125 Unit with Carbo-Max® 1000 Bulk CO₂ System

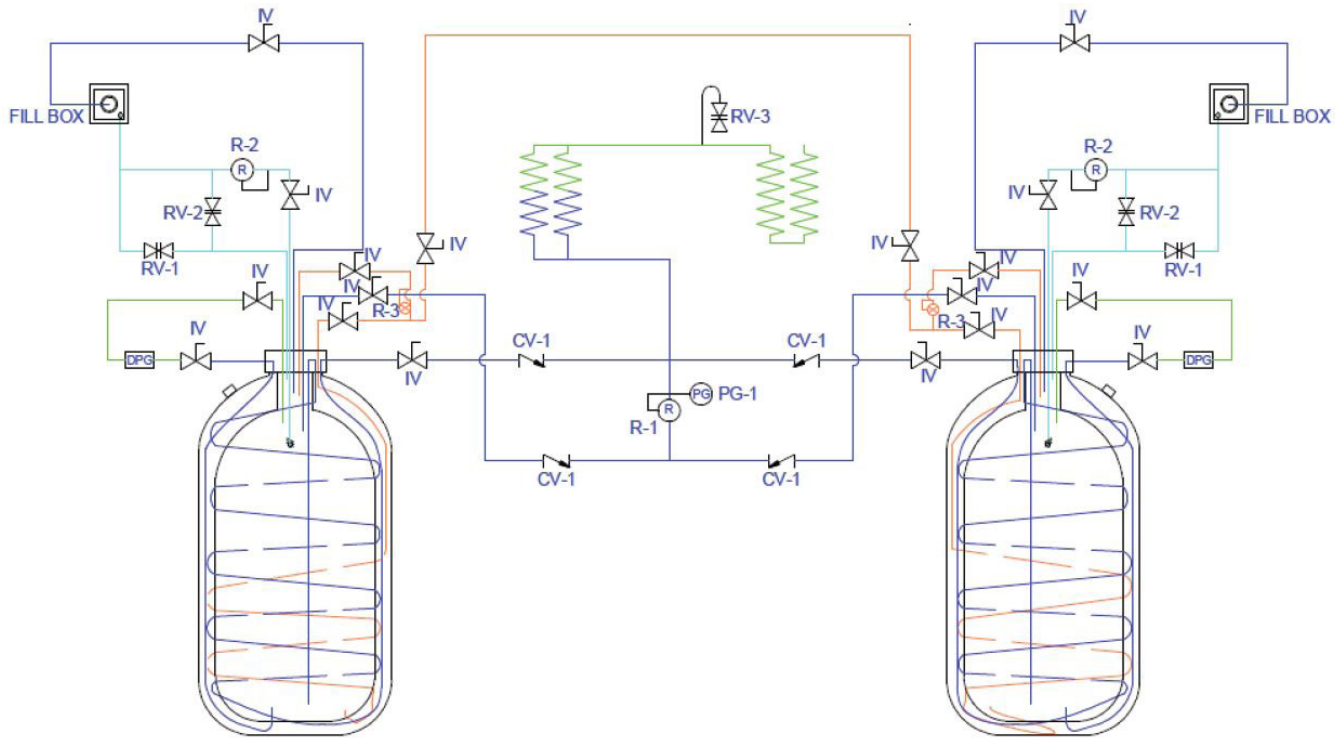

Nomenclature	
Designation	Description
CV-1	VALVE CHECK BRS 1/2FPT*1/2FPT PN 11051090
PG-1	PG 2" DIAL 0-600 PSI 1/4" MPT CBM PN 11940305
R-1	REGULATOR 250 NPT @ 150 PSI ECON PN 13154842
R-2	REGULATOR 250 NPT @ 200 PSI SF PN 13154834
R-3	REGULATOR 250 NPT @ 125 PSI PB PN 14743180
RV-1	RV BRS 1/2MPT 300 PSI PN 11708400
RV-2	RV BRS 1/2MPT 450 PSI PN 11708451
RV-3	RV BRS 1/4MPT 450 PSI GENERANT PN 11193055
DPG	DIFF PG 0-50" 1/8"FPT FULL PN 15096551
IV	VALVE ISOLATION BRS ABCO PN 20733160

*PED model equipped with two relief valves (PN 20986538) 20.68 bar each

VaporMan 125 Unit with Perma-Cyl® MicroBulk Storage System

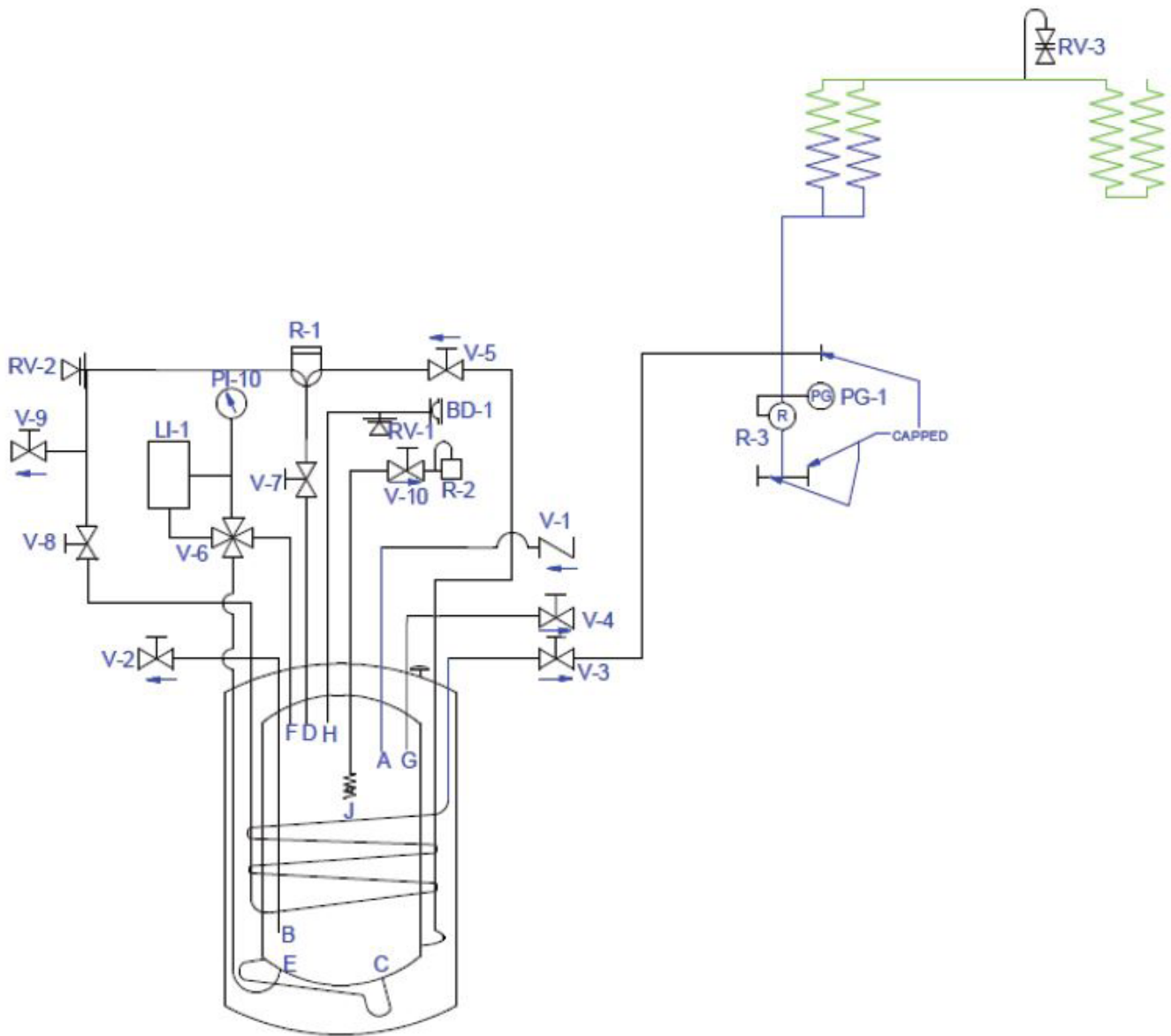

Nomenclature	
Ref. No.	Description
V-1	TOP FILL CHECK VALVE
V-2	LIQUID VALVE
V-3	GAS USE VALVE
V-4	VENT/FULL TRYCOCK VALVE
V-5	PRESS. BLDG. VALVE
V-6	4-WAY VALVE
V-7	REG. ISO VALVE PB
V-8	REG. ISO VALVE ECON
V-9	PB PURGE VALVE
V-10	SUREFILL ISOLATION VALVE
LI-1	LEVEL INDICATOR
PI-1	PRESSURE INDICATOR
R-1	PRESS BUILDING REG.
R-2	SUREFILL REG
RV-1	RELIEF VALVE
RV-2	LINE RELIEV
BD-1	BURST DISC

Piping	
Ref. No.	Description
A	TOP FILL
B	LIQUID WITHDRAWAL
C	PRESSURE BUILDING INLET
D	PRESSURE BUILDING OUTLET
E	LIQUID PHASE
F	VAPOR PHASE
G	VENT/FULL TRYCOCK
H	SAFETY CIRCUIT
I	SUREFILL

Nomenclature	
Designation	Description
PG-1	PG 2" DIAL 0-600 PSI 1/4" MPT CBM PN 11940305
RV-3	RV BRS 1/4MPT 450 PSI GENERANT PN 11193055
R-3	REGULATOR .250NPT @ 150 PSI ECON PN 13154842
R-1	REGULATOR .250NPT @ 150 PSI ECON PN 13154842

Set-up and Dimensions

VaporMan 125® Unit

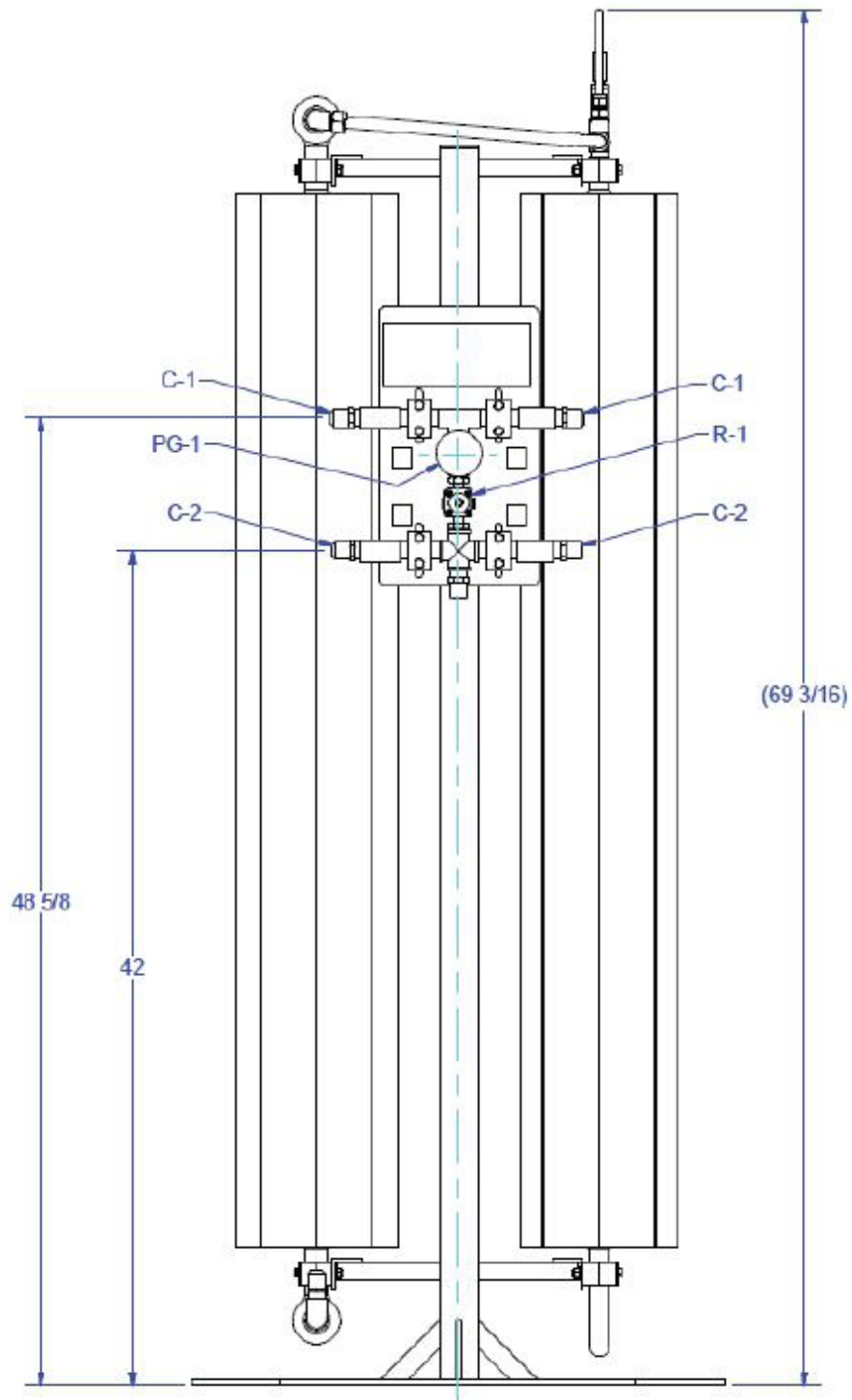

VaporMan 125 Unit with Carbo-Max[®] 750 Bulk CO₂ System

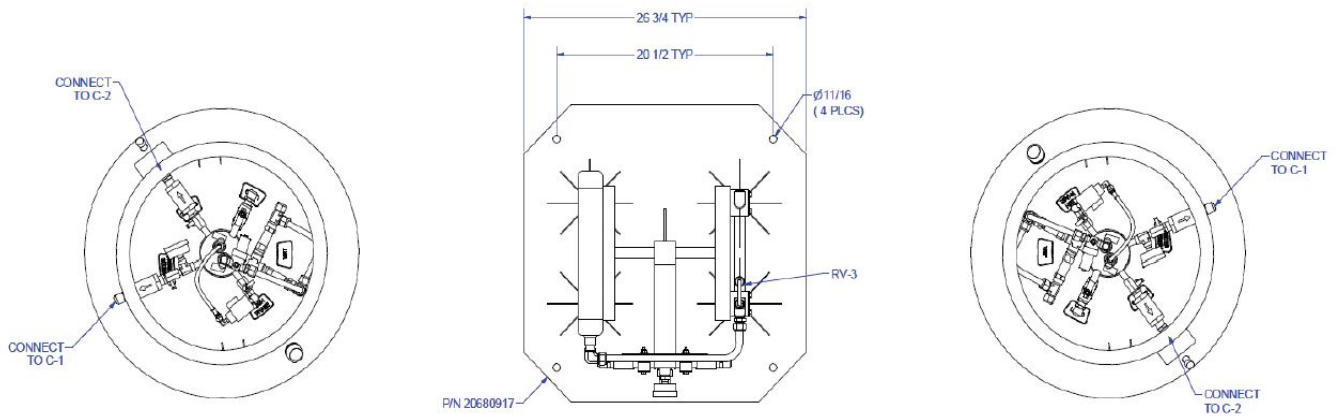

VaporMan 125 Unit with Carbo-Max[®] 1000 Bulk CO₂ System

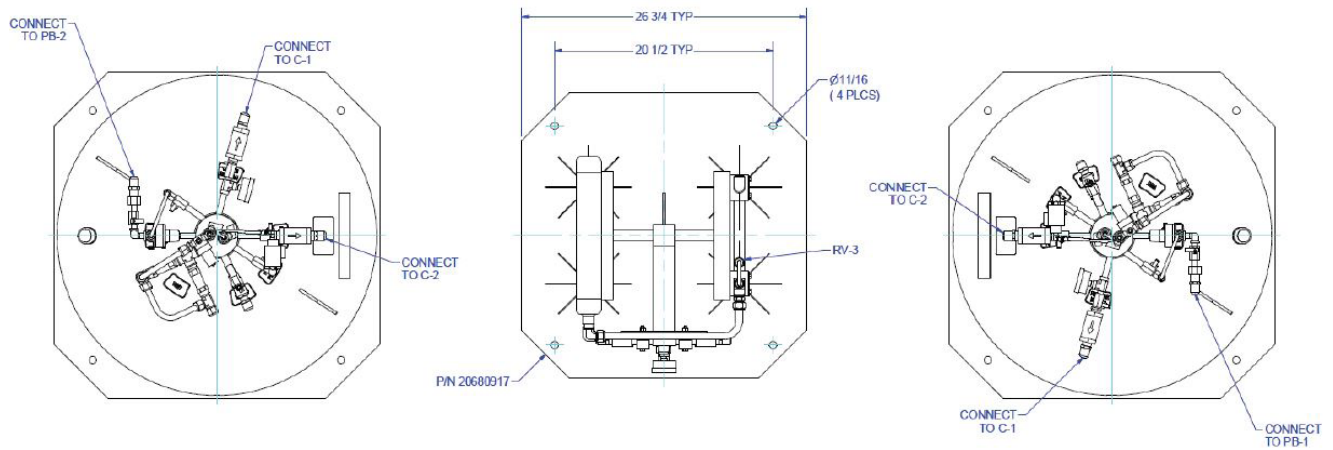

VaporMan 125 Unit with Perma-Cyl® MicroBulk Storage System

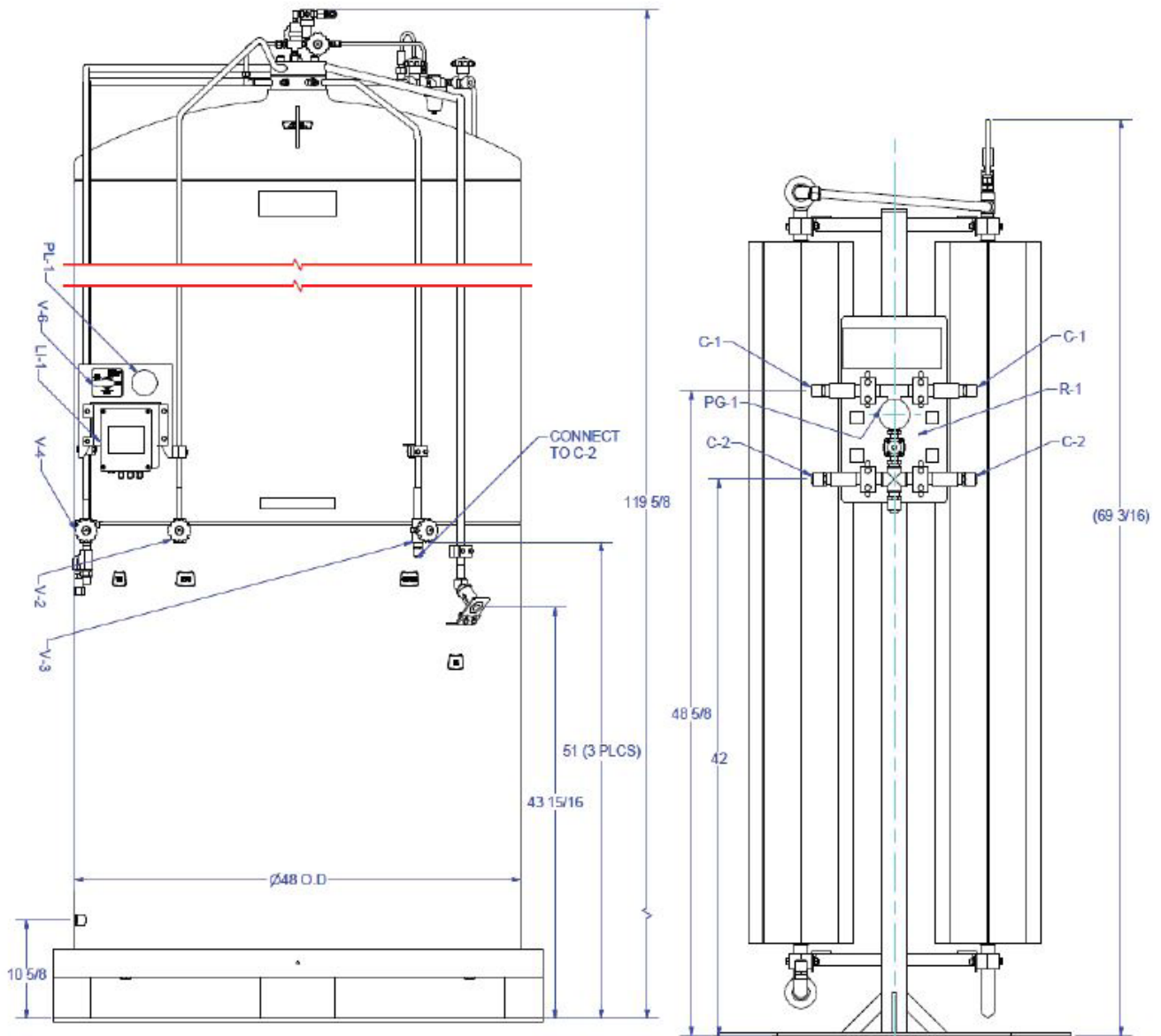

Warranty

Warranty Policy

Chart Inc. (“Chart”) warrants to the Purchaser that the Bulk CO₂ Storage Systems equipment (the “Equipment”) shall be free from any defects in workmanship and materials; provided, however, that this warranty shall be limited to Equipment found to be defective within a period of one (1) year from initial use or eighteen (18) months from the date of shipment, whichever expires first, except that parts sold as a spare or for replacement are warranted for ninety (90) days from the date of shipment. Chart also warrants the vacuum in the Equipment for five (5) years from the date of the original Chart invoice. Chart warrants that its services will be performed in a professional and workmanlike manner. All Chart services are warranted for a period of ninety (90) days from the date of their completion.

Purchaser agrees that as a pre-condition to any Chart liability hereunder, Purchaser or its appointed agents shall fully inspect all Equipment immediately upon delivery and shall give Chart written notice of any claim or purported defect within ten (10) days after discovery of such defect.

As a further pre-condition to any Chart liability hereunder, an approved Chart service company must supply both parts replacement and labor and Purchaser must strictly adhere to the Warranty Claims Procedure set forth below. Chart’s sole and exclusive liability under this limited warranty is to the original Purchaser only and is, at Chart’s sole option: (1) repair or replacement of the defective Equipment or parts thereof; or (2) refund the net purchase price of the defective Equipment or parts thereof paid by the original Purchaser; or (3) in the case of nonconforming services, provide equivalent services or refund the net price paid by the original Purchaser for such services. Chart shall not be responsible for providing working access to the defect, including disassembly and reassembly of Equipment or for providing transportation to and from Chart’s repair or factory facility, all of which shall be at Purchaser’s risk and expense.

This limited warranty does not apply to Equipment that Chart determines to have been caused by the effects of normal wear and tear, erosion, corrosion, fire, flood, explosion or other excessive external forces, misuse, abuse, negligence or accident. Alterations or repairs by any party other than those designated and approved in writing by Chart, or installation, storage, maintenance or operation of such Equipment in a manner inconsistent with Chart accepted practices, normal operating instructions, specifications and drawings, or outside the specified design conditions, unless pre-authorized in writing by Chart, shall void this limited warranty. Modifications in any way to the Equipment without Chart’s prior written approval shall render this warranty void. This limited warranty does not apply to Equipment comprised of materials provided or a design stipulated by Purchaser

or to Equipment purchased used. Negligent handling of the vacuum by the Purchaser or others, or testing of the vacuum levels by any party other than Chart designated and approved party shall render the vacuum warranty void.

Repairs or replacements made pursuant to warranty shall not renew or extend the applicable original warranty period; provided however, that any such repairs or replacement of Equipment or parts thereof shall be warranted for the time remaining in the original warranty period or thirty days, whichever is longer.

Individual parts replacements under warranty and with a component list price less than \$50.00 will be replaced at no charge. Individual components costs exceeding \$50.00 that are replaced under warranty will be invoiced to the Purchaser and the Purchaser will be issued credit based on results of Chart’s evaluation of the returned component(s). The Return Material Authorization (RMA) process must be initiated prior to shipment of any replacement parts.

Chart is not liable for component replacement labor exceeding two hours for actual replacement and two hours travel time (four hours @ 65.00/hour maximum).

Chart specifically makes no warranties or guarantees, expressed or implied, including the warranties of merchantability of fitness for a particular purpose or use, or warranties arising from course of dealing or usage of trade, which are all expressly disclaimed, other than limited warranties expressly specified herein.

In no event shall Chart be liable for any special, indirect, incidental or consequential damages, including but not limited to loss of profits, lost opportunity, loss of use of the equipment, CO₂ loss, cost of capital, cost of substitute equipment, downtime costs, costs of delays nor for any penalties, whether any such claim for the same is based on contract, warranty, tort, negligence, strict liability or otherwise, Chart’s liability for any such claims whether in contract, warranty, negligence, tort, strict liability, or otherwise or for any loss or damage arising out of, connected with, or from any design, sale, installation, operation or use of the equipment or performance of any services rendered by Chart, shall in no event exceed the purchase price paid to Chart by purchaser for the specific equipment or part thereof or for the services giving rise to the claim. Purchaser agrees to defend, indemnify and hold Chart harmless from any third party claims arising out the use, sale, or lease of the equipment.

This warranty policy is not intended to replace or supersede the warranties, limitations, exclusive remedy and disclaimers set forth in Chart’s Terms and Conditions of Sale. In the event of a conflict between Chart’s Terms and Conditions

of Sale and this Warranty Policy, this Warranty Policy shall control.

Warranty Claims Procedure

1. All warranty claims must be previously authorized by Chart Inc. Telephone / electronic approval may be obtained by contacting Chart's Beverage Systems Technical / Customer Services at:

1-800-247-4446

1-800-253-1769

Fax: 1-952-758-8275

Or by writing to:

Chart Inc.

407 7th Street NW

New Prague, MN 56071
2. Authorization must be obtained from Chart prior to shipping any Equipment to Chart facilities. In order to process the return of a tank its model and serial number must be provided. If approved, a Return Material Authorization (RMA) number will be provided. The RMA number must be prominently indicated on the packing slip and any packaging that accompanies the goods being returned. The customer returning the goods is responsible for all freight, proper packing, and any damage incurred during shipment of the goods back to Chart.

