



PERMANENT MEDIA FILTER OWNER'S MANUAL

Installation, Operating and Service Instructions



For R (36" Dia.), L (42" Dia.), S (42" Dia.), 4X (48" Dia.), 5X (60" Dia.) Vessels.

WARNING: This manual contains critical safety information that must be furnished to the end user. Failure to read and follow the instructions could result in serious personal injury and major property damage.

Thinking Toward the Future, Changing With the Times.



1351 Rt. 55, LaGrangeville, NY 12540
Phone: 845.452.5500 • Fax: 845.452.5426
www.paragonaquatics.com

TABLE OF CONTENTS

| | |
|---|-----------|
| 1 Basic Principles of Operation | 5 |
| 1.1 Filtration – How Your Filter Works | 5 |
| 1.2 Backwash | 6 |
| 1.3 Principles of Operation | 7 |
| <i>1.3.1 Diaphragm Valve Operation</i> | 7 |
| <i>1.3.2 Single Tank – Normal Operation</i> | 7 |
| <i>1.3.3 Single Tank – During Backwash</i> | 7 |
| <i>1.3.4 Dual Tank – Normal Filtration</i> | 8 |
| <i>1.3.5 Dual Tank – During Backwash</i> | 8 |
| <i>1.3.6 Multiple Tank – Normal Filtration</i> | 9 |
| <i>1.3.7 Multiple Tank – During Backwash</i> | 9 |
| 2 Installation and Assembly | 10 |
| 2.1 Receiving and Inspecting | 10 |
| 2.2 Locating the Filter | 10 |
| 2.3 Setting Anchor Bolts | 13 |
| 2.4 Installation of Face Piping | 13 |
| 2.5 Backwash Controller Installation | 15 |
| <i>2.5.1 Semi-automatic Controller (CM200) – Single Tank Installation</i> | 15 |
| <i>2.5.2 Semi-Automatic Controller (CM200) – Dual Tank Installation</i> | 20 |
| <i>2.5.3 Semi-Automatic Controller (CM200) – Multiple Tank Installation</i> | 23 |
| <i>2.5.4 Automatic Controller (CA100) – Single Tank Installation</i> | 26 |
| <i>2.5.5 Automatic Controller (CA100) – Dual Tank Installation</i> | 30 |
| <i>2.5.6 Automatic Controller (CA100) – Multiple Tank Installation</i> | 34 |
| <i>2.5.7 Backwash Controller (CS400) – Single Tank Installation</i> | 38 |
| <i>2.5.8 Backwash Controller (CS400) – Dual Tank Installation</i> | 42 |
| <i>2.5.9 Backwash Controller (CS400) – Multiple Tank Installation</i> | 46 |
| 2.6 Operation (Semi-Autonomous Controller) | 50 |
| 2.7 Inspection of Components | 54 |
| 2.8 Pressure Test System | 55 |
| 2.9 Media Installation | 55 |
| 3 Start-up and Operation | 56 |
| 3.1 Backwash System | 56 |
| 3.2 Return Filters to Normal Filtration Mode | 56 |

| | |
|--|-----------|
| 4 Maintenance | 57 |
| 4.1 Periodic Backwash | 57 |
| 4.2 Periodic Inspection of Filters | 58 |
| 4.3 Draining the Filters | 59 |
| 4.4 Installation/Removal of Manway Cover | 59 |
| 4.5 Removal of Sand Media | 60 |
| 4.6 Winterizing the Filter Tanks | 60 |
| | |
| APPENDIX | 61 |
| APPENDIX A: Pressure Drop Curves | 62 |
| APPENDIX B: Media Requirements (for sand and gravel) | 73 |
| APPENDIX C: Troubleshooting | 74 |
| APPENDIX D: Backwash Log | 75 |
| APPENDIX E: Tank Specifications | 76 |
| RS/SS-Series (36"/42" Diameter, Wound) | |
| L-Series (42" Diameter, Unwound) | |
| S-Series (42" Diameter, Wound) | |
| 4X-Series (48" Diameter) | |
| 5X-Series (60" Diameter) | |
| 5S-Series (60" Diameter) | |
| APPENDIX F: Tank Part Drawings | 77 |
| RS/SS-Series (36"/42" Diameter, Wound) | |
| L-Series (42" Diameter, Unwound) | |
| S-Series (42" Diameter, Wound) | |
| 4X-Series (48" Diameter) | |
| 5X-Series (60" Diameter) | |
| 5S-Series (60" Diameter) | |
| APPENDIX G: Replacement Parts | 78 |
| Face Piping | |
| Controls | |
| Valves | |
| APPENDIX H: Hydraulic Valve Piping Schematics | 79 |

IMPORTANT WARNING AND SAFETY INSTRUCTIONS



Important Notice:

This guide provides installation and operation instructions for the Stark™ Series Filters. Consult Pentair Commercial Aquatics™ with any questions regarding this equipment.

Attention Installer: This guide contains important information about the installation, operation and safe usage of this product. This information should be given to the owner and/or operator of this equipment after installation or left on or near the filter.

Attention User: This manual contains important information that will help you in operating and maintaining this filter. Please retain it for future reference.



WARNING Before installing this product, read and follow all warning notices and instructions which are included. Failure to follow safety warnings and instructions can result in severe injury, death, or property damage. Call (800) 333-8125 for additional free copies of these instructions.

Consumer Information and Safety

These filters are designed and manufactured to provide many years of safe and reliable service when installed, operated and maintained according to the information in this manual and the installation codes referred to in later sections. Throughout the manual, safety warnings and cautions are identified by the ⚠ symbol. Be sure to read and comply with all of the warnings and cautions.



THIS FILTER OPERATES UNDER HIGH PRESSURE

When any part of the filtration system, (e.g., closure, pump, filter, valve(s), etc.), is serviced, air can enter the system and become pressurized. Pressurized air can cause the top closure to separate which can result in severe injury, death, or property damage. To avoid this potential hazard, follow these instructions:



1. If you are not familiar with your filtration system filtering system:
 - a. **Do NOT** attempt to adjust or service without consulting your dealer, or a qualified filtration system technician.
 - b. Read the entire Installation & User's Guide before attempting to use, service or adjust the filtering system.
2. Before repositioning valve(s) and before beginning the assembly, disassembly, or any other service of the filtration system: (A) Turn the pump **OFF** and **shut OFF** any automatic controls to ensure the system is NOT inadvertently started during the servicing; (B) open the manual air bleeder valve; (C) wait until all pressure is relieved.
3. Whenever installing the filter closure **FOLLOW THE FILTER CLOSURE WARNINGS EXACTLY.**
4. Once service on the filtration system is complete **FOLLOW INITIAL START-UP INSTRUCTIONS EXACTLY.**
5. Maintain filtration system properly. Replace worn or damaged parts immediately, (e.g., closure, pressure gauge, valve(s), o-rings, etc).
6. Be sure that the filter is properly mounted and positioned according to instructions provided.

IMPORTANT WARNING AND SAFETY INSTRUCTIONS

⚠ WARNING

This filter must be installed in accordance with the all applicable local codes and ordinances. Improper installation could result in death or serious injury to users, installers, or others and may also cause damage to property.

Always disconnect power to the filtration system at the circuit breaker before servicing the filter. Ensure that the disconnected circuit is locked out or properly tagged so that it cannot be switched on while you are working on the filter. Failure to do so could result in serious injury or death to service person, users or others due to electric shock.

⚠ WARNING

Do not operate the filter until you have read and understand clearly all the operating instructions and warning messages for all equipment that is a part of the filtration system. The following instructions are intended as a guide for initially operating the filter in a general filtration system installation. Failure to follow all operating instructions and warning messages can result in property damage or severe personal injury or death.

⚠ WARNING

To reduce the risk of injury, do not permit children to use this product.

Never attempt to adjust any closures or lids or attempt to remove or tighten bolts when the system is pressurized. These actions can cause the closure to separate and could cause severe personal injury or death if they were to strike a person.

⚠ WARNING

Never exceed the maximum operating pressure of the system components. Exceeding these limits could result in a component failing under pressure. This instantaneous release of energy can cause the closure to separate and could cause severe personal injury or death if they were to strike a person.



Thank you for purchasing your new Stark™ High Rate Sand Filter from Pentair Commercial Aquatics™. Your new filter vessel is the best that money can buy, with its ability to operate for years with a minimum amount of maintenance, as well as having excellent resistance to corrosion due to its all fiberglass construction. In this manual you will learn the basic principles on how your new filter operates, as well as how to install, operate, and maintain it. We suggest reading this manual through once to familiarize yourself with it before proceeding with installation and operation. Again, thank you for purchasing your high rate sand filter from Pentair Commercial Aquatics.

1 Basic Principles of Operation

Your high rate sand filter is designed to operate for years with a minimum amount of maintenance when installed, operated and maintained in accordance with these instructions.

1.1 Filtration - How Your Filter Works

The basic principles of filter operation are as follows:

Dirty water enters the filter tank by being pumped under pressure through the influent pipe and is distributed across the top of the inner tank chamber through diffusers. The water is then forced downward through the sand filter bed. Dirt and debris is collected in the sand bed allowing clean water to pass through. The clean water then passes through the collection laterals and exits the filter through the effluent piping and is returned to the pool.

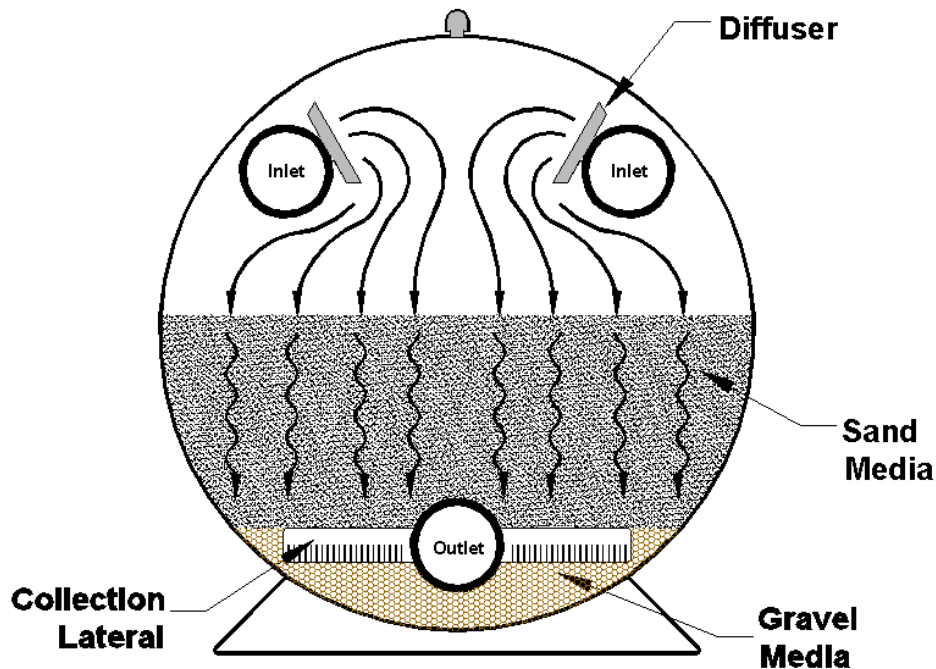

Tank Cross Section During Normal Filtration
(Shown as Reference only, actual internal piping may differ)

The pressure in the Stark™ High Rate Sand Filter will increase and the flow of water through the filter will diminish as dirt accumulates in the filter. Eventually, the filter will become obstructed enough with dirt that it will become necessary to backwash the filter.

Please note that a filter removes suspended matter but it does not sanitize the pool. The pool water must be sanitized and the water must be chemically balanced for optimum water clarity. Your filtration system should be designed to meet your local health codes. Pool chemistry is a specialized area and you should consult your local pool service specialist for specific details.

1.2 Backwash

The basic principal of filter backwash is to reverse the flow of water through the filter. This will remove the dirt and debris trapped in the filter bed. For this principal to work properly a flow of 15-20 GPM per square foot of filter area should pass through the filter in the reverse direction. This will help to fluidize the sand bed, loosening any solids trapped or compacted in the bed, and then lifting the solids and transporting them out of the filter to waste. Usually a two to five minute backwash duration is all that is necessary to clean the filter. **Please note, it is absolutely necessary to have a large enough waste line to accommodate the backwash flow rate of the filter.**

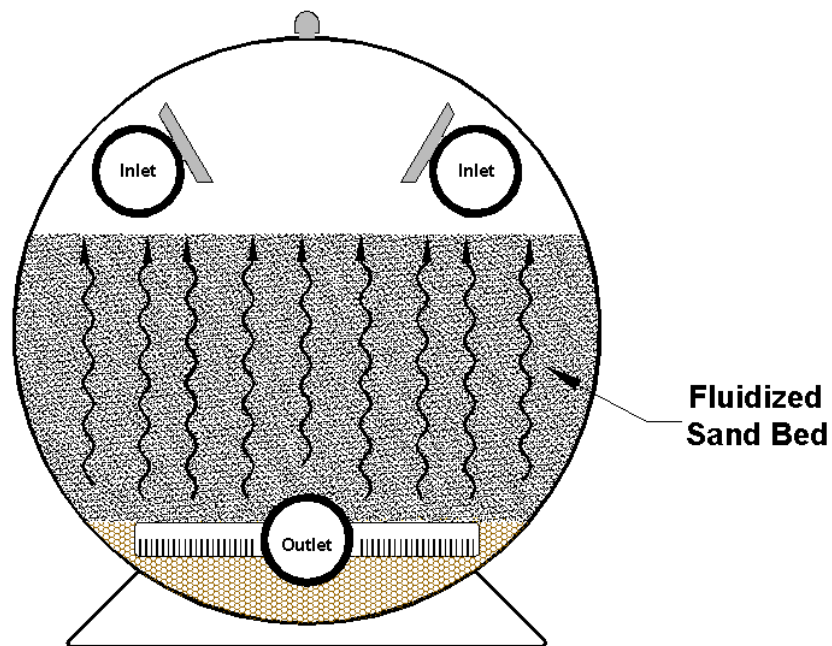

Tank Cross Section During Backwash Mode
(Shown as Reference only, actual internal piping may differ)

1.3 Principals of Operation

This section will familiarize you with how the face piping kit and valves work in order to provide a means of backwashing the Stark™ High Rate Sand Filter. It will cover how the diaphragm valves operate, the flow of water in a single tank system in normal filtration and backwash modes, a dual tank system in normal filtration and backwash modes, and a multiple tank system in normal filtration and backwash modes. **Please note that the diagrams are for reference only, and may not be representative of the actual face piping kit.**

1.3.1 Diaphragm Valve Operation

During normal operation, water enters one side of the valve and exits the other. A shaft, which is attached to a diaphragm at one end, and a throttling cone and seal at the other, prevents water from flowing out of the sideport. When the valve is actuated, water is pumped into the top of the valve from the controller. This water and pressure causes the diaphragm to collapse onto the sealing surface of the valve body. This moves the cone portion of the shaft allowing water to exit out of the sideport, while sealing off flow from the influent side of the valve.

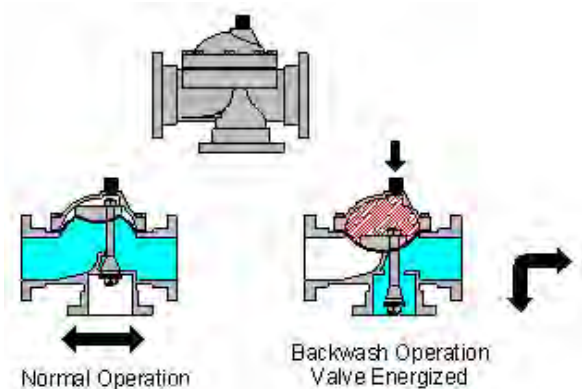

1.3.2 Single Tank - Normal Operation

During normal filtration mode, water is passed through the influent piping and into the tank. Water is then passed through the sand, which is what actually filters the water. It is then passed through the collection laterals at the bottom of the tank. It then passes out of the effluent pipe and continues on through the rest of the filtration system.

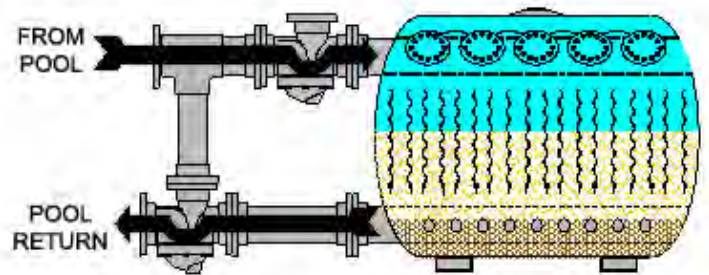

1.3.3 Single Tank - During Backwash

During backwash mode, both of the diaphragm valves are actuated. Since water cannot enter the tank through the influent piping, it enters through the effluent piping. The water is pushed up through the sand bed, which is called "fluidizing" the sand bed. This loosens dirt and debris trapped by the sand. This debris is then passed through the influent piping and exits through a waste pipe connected to the valve.

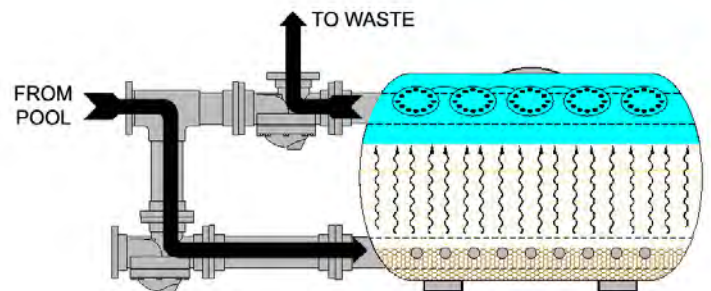

1.3.4 Dual Tank - Normal Filtration

During normal filtration in a dual tank system, water is split between the two tanks. It passes through the influent piping and then through the sand beds. It is then passed through the collection laterals at the bottom of the tanks and passed out of the effluent piping and returned to the pool.

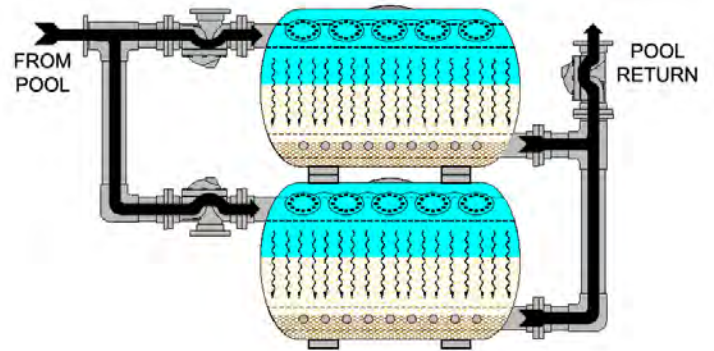

1.3.5 Dual Tank - During Backwash

During backwash mode in a dual tank system, one of the three way valves and the two-way valve are actuated simultaneously. This allows water to pass through one of the filters as if it were filtering normally. When the water exits that tank, it is forced to enter the second tank through the effluent pipe. This water then backwashes the second tank. The dirt and debris is then passed through the influent pipe of tank two and out of a waste pipe connected to the valve.

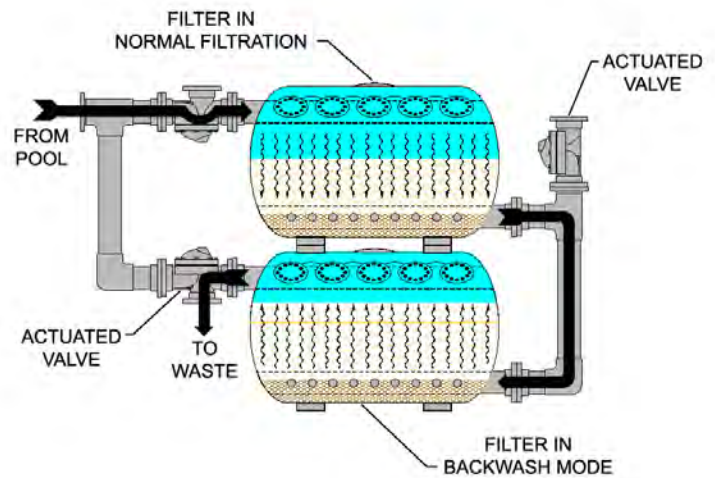

1.3.6 Multiple Tank - Normal Filtration

During normal filtration in a multiple tank system, water is split between the multiple tanks. It passes through the influent piping and then through the sand beds. It is then passed through the collection laterals at the bottom of the tanks and passed out of the effluent piping and returned to the pool.

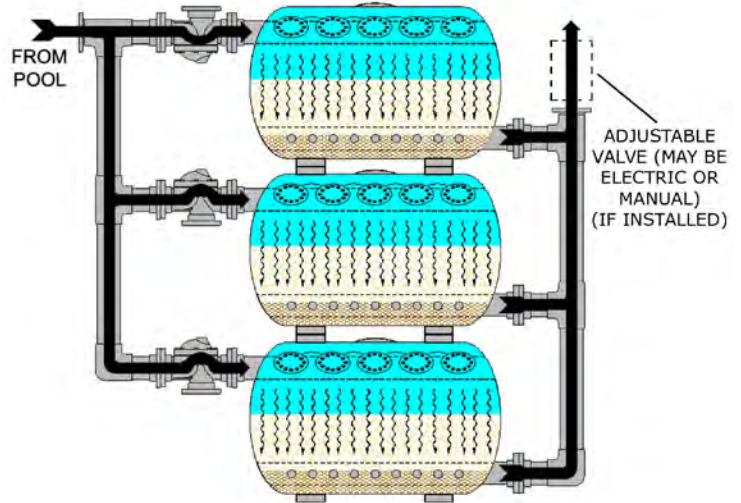

1.3.7 Multiple Tank - During Backwash

During backwash mode in a multiple tank system, one of the three way valves and an adjustable valve (if equipped) are actuated simultaneously. This allows water to pass through the remaining filters as if it were filtering normally. When the water exits those tanks, it is forced to enter the backwash tank through the effluent pipe. This water then backwashes the individual tank. The dirt and debris is then passed through the influent pipe of the backwash tank and out of a waste pipe connected to the valve.

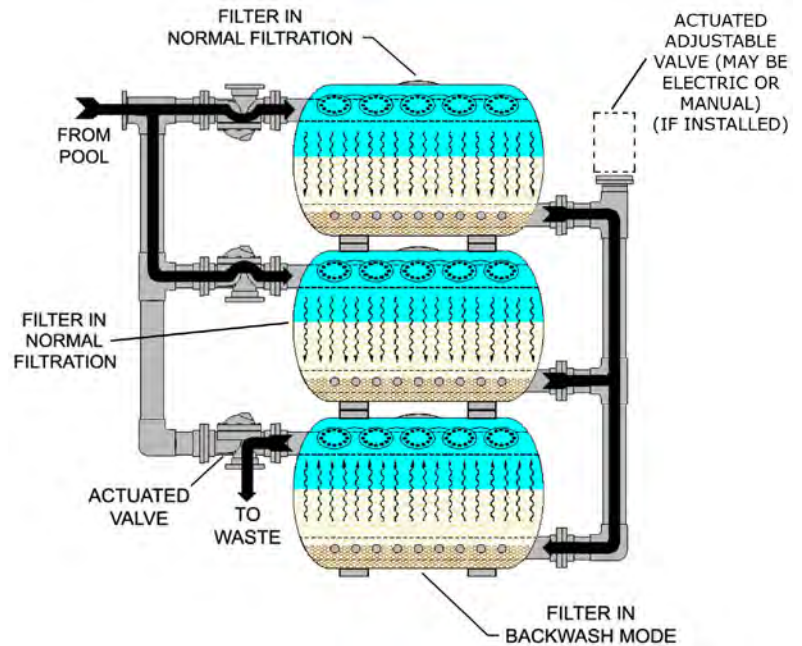

2 Installation and Assembly

If you have purchased the vessel(s) with the optional face piping kit, please refer to additional documentation provided with the face piping kit.

2.1 Receiving and Inspecting

- Upon receipt of Stark™ High Rate Sand Filter(s), check the filter pallet(s) and auxiliary cartons for any evidence of damage due to rough handling in shipment. If the filter(s) or any filter components are damaged, NOTIFY FREIGHT CARRIER IMMEDIATELY.
- Verify that you have all equipment contained on the Packing List(s) and that there is no apparent damage to this equipment.

NOTE: BEFORE BEGINNING INSTALLATION, MAKE SURE PROPER SAFETY EQUIPMENT IS BEING USED.

2.2 Locating the Filter

- Prior to installing the filter(s), be sure to provide a PERMANENT LEVEL SLAB on which to mount the filter. Preferably the slab should consist of reinforced concrete poured in a form. Alternately, the filter(s) can be mounted on a platform constructed of concrete block or brick. The platform must be able to support the weight of the entire system (including media and water). DO NOT use sand to level the filter(s) or for pump mounting, as it will wash away.
- Position the concrete slab so that the instructions, warnings and the pressure gauges on the system will be visible to the operator. It should be positioned so that the piping connections, manway, and drain are convenient and accessible for servicing and winterizing. If possible, ensure that the filter(s) are positioned to accommodate any rough plumbing that may have been previously installed. Dimensions 'A' and 'B' in Figure 1 (next page) give the minimum filter to wall clearance in order to maintain a 6" minimum clearance between the tank and the wall (or other equipment). These are only given as minimum distance guidelines. Tanks may be set up at larger clearances if desired.

IMPORTANT: If a pre-glued diaphragm valve face piping kit (for RS, SS and 5S Series vessels) has been purchased, it is very important that the center to center ("C-C") of the tanks be held to the dimension listed in Figure 1. Failure to do so may cause the piping kit not to fit properly.

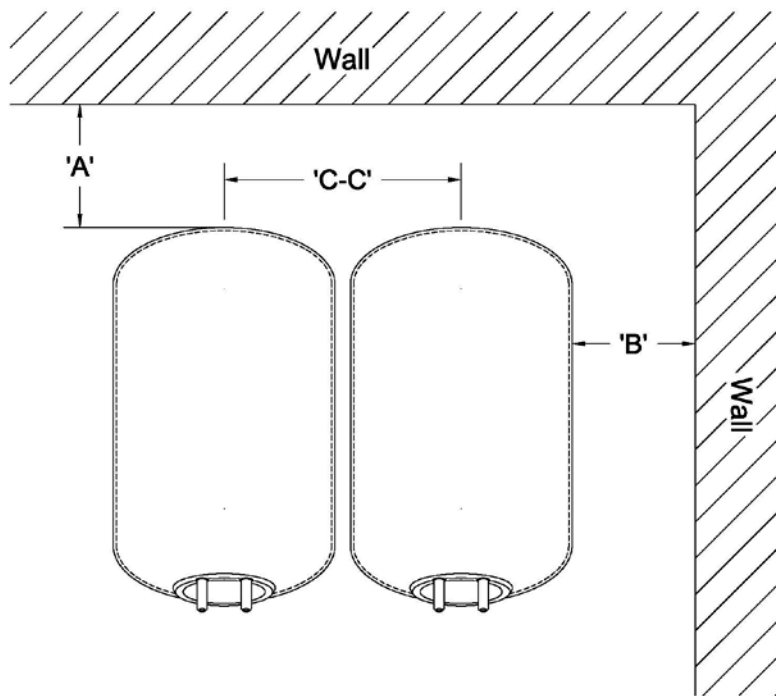
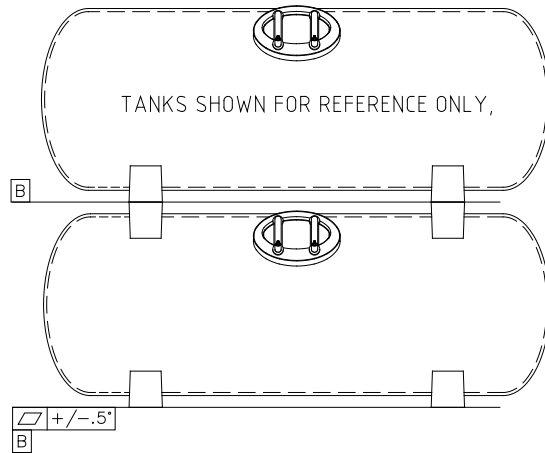
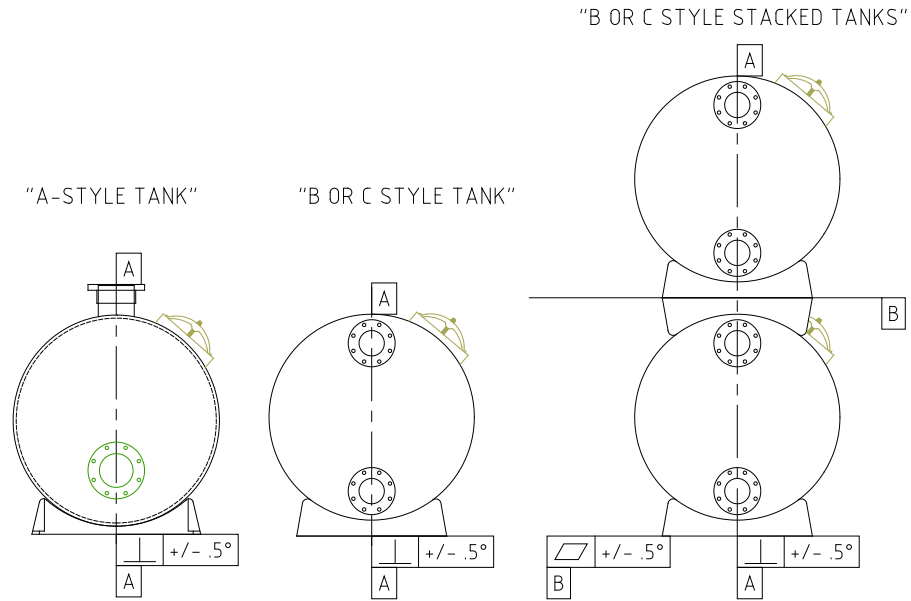

Figure 1

| Model | "A" (in.) | "B" (in.) | "C-C" (in.) |
|-------|--------------|--------------|----------------|
| RS60 | 6 | 6 | 39 |
| RS72 | | | 46 1/4 |
| SS48 | | | |
| SS96 | | | |
| SS96 | | | 66 |
| 5S30 | | | |
| 5S35 | | | |
| 5S40 | | | |
| 5S45 | | | |
| 5S50 | | | |

- For "S" vessels, ensure that the tank(s) are level, both across each pipe connection and from the influent pipe to the effluent pipe. For two tank systems, make sure the tanks are level to each other. **If adjustments need to be made, safely lift vessel with proper rigging techniques to allow access to bottom (also top if base tank) loosen the nut underneath the saddles and adjust the saddle placement as needed.** Be sure to tighten the nut until lock washer is fully compressed after adjustment. If shimming is required to raise one end of the tank, be sure to use a non-compressible material placed under the bottom of the tank saddle.
- For "A, B and C" vessels, ensure that the tank(s) are level, both across each pipe connection and from the influent pipe to the effluent pipe See Figure 1A. For two tank systems, make sure the tanks are level to each other. **If adjustments need to be made, safely lift vessel with proper rigging techniques to allow access to bottom (also top if base tank) loosen the nut underneath the saddles and adjust the saddle placement as needed.** Be sure to tighten the nut until lock washer is fully compressed after adjustment. If shimming is required to raise one end of the tank, be sure to use a non-compressible material placed under the bottom of the tank saddle.

FIGURE 1A



2.3 Setting Anchor Bolts

NOTE: Local, county, and state codes may require that the tanks be anchored in a specific way. Please verify before proceeding with anchor installation.

- If the tanks are to be anchored to the slab, mark the holes when the tanks are in their desired position on the slab. Install anchors per manufacturer's specifications.

NOTE: Move the tanks aside before drilling for anchors. This may be necessary in order to comply with the anchor manufacturer's instructions, and will avoid damage to the tanks and/or saddles during anchor installation.

2.4 Installation of Face Piping (If provided with Stark™ High Rate Sand Filter).

NOTE: Unless the optional piping kit was purchased from the filter manufacturer, which provides the valves and piping to facilitate proper backwash and filtration operation, the filter manufacturer cannot accept responsibility for the design, installation, and operation of same.

Plastic piping systems should be **ENGINEERED, INSTALLED, and OPERATED** in accordance with **ESTABLISHED DESIGN AND ENGINEERING STANDARDS AND PROCEDURES** for plastic piping systems. Suitability for the intended service application should be determined prior to installation.

IMPORTANT – WATER HAMMER – Paragon recommends that all plastic piping systems be designed and constructed to **AVOID EXCESSIVE WATER HAMMER**. Water hammer can cause damage and failure to pipes, valves, and fittings within the piping system. **All pipes should be secured with adequate bracing and hangers to prevent damage to system from weight and vibrations. Failure to do so may affect warranty.**

- Each filter system has custom face piping and the accompanying submittal drawing should be consulted when assembling the face piping.
- For systems that do not come pre-glued by factory, the face piping is all pre-cut at the factory and needs to be glued on site to the fittings. This allows the installer some flexibility on the auxiliary piping configuration during the final assembly. Some pieces have been left slightly longer than necessary to allow field trimming.

SOLVENT WELD CONNECTIONS – Use a quality grade of primer and solvent cement formulated for the type of connection, with the **CORRECT SIZE APPLICATOR**. Read and follow all of the solvent cement **MANUFACTURER'S APPLICATION INSTRUCTIONS**.

THREADED CONNECTIONS – Use a quality grade of Teflon tape recommended by the manufacturer for use with plastic. **DO NOT USE OIL BASE PIPE JOINT COMPOUND OR TEFLON PASTE** – they may contain substances that could cause **STRESS CRACKING** to plastics. A 1-1 ½ turn beyond hand tight is generally all that is required to make a sound plastic threaded connection. Unnecessary **OVERTIGHTENING** will cause **DAMAGE TO BOTH PIPE AND FITTING**.

- Flange Make up – once a flange is joined to pipe, the method of joining two flanges is as follows:
- **Piping runs joined to the flanges must be installed in a straight-line (flanges must be parallel) to avoid stress at the flange due to misalignment. Once installed, all piping must be fully supported with bracing and hangers (by others) to prevent damage to the system from weight and vibration.**
- Align the bolt holes of the mating flanges by rotating the ring into position.
- Make sure the faces of the mating surfaces are not separated by excessive distance prior to bolting down the flanges.
- Make sure to install a gasket between the flanges. The typical gasket is 1/8" thick neoprene.
- **Stark plastic flange bolts are designed for 25 ft/lbs torque working pressure. If more torque is necessary, substitute with stainless steel bolts.**

Tighten the bolts on the plastic flanges by pulling down the nuts diametrically opposite each other using a torque wrench. Tighten bolts according to the sequence shown in the diagram. Completed tightening should be accomplished in stages and the final torque values followed according to the size of the flange. Uniform pressure across the flange will eliminate leaky gaskets.

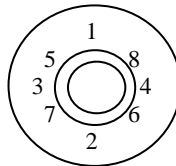

- Groove Coupling Make up- Refer to Figure below for assembly. Use anti-seize on threads of all Stainless Steel hardware.

Valve Installation

- Per the submittal drawing, the valves provided should be bolted in place to the face piping. Ensure valve orientation and flow direction (shown by an arrow on the valve) is correct for your application. **In standard applications, the arrow on the 3-way valves should always point towards the tank.**
- The Stark valve is a simple design with few moving parts to wear out that can be modulated using hydraulic pressure from a simple city water line providing **35-50 psi**. (If this pressure is unavailable, A PBS system may be purchased. Please contact your local Stark Distributor for assistance)
- **To control the valves, refer to the Backwash Controller Installation section of this manual (see appropriate schematic in Appendix H either automatic or semi-automatic) a domestic water line should be run through the pressure regulator/reducer and an in-line check valve to the center port on the multi-port valve, all of which are provided on the standard Stark filtration system.**
- **If not provided, it is highly recommended that a PVC ball valve be installed on the manual air relief located on the top portion of the tank. This is added to assist in relieving air from the tank while filling with water.**

2.5 Backwash Controller Installation

NOTE: This section covers the installation of semi-automatic and automatic backwash controllers for single tank, dual tank and multiple tank systems.

2.5.1 Semi-automatic Controller (CM200) - Single Tank Installation

The single tank semi-automatic controller kit consists of the following:

- (1) Controller gauge panel
- (2) 3/8" OD tube quick connect tees
- (3) 3/8" OD x 1/4" MNPT quick connect fittings
- (1) Check valve w/ fittings
- (100 ft) 3/8" OD polyethylene tube



Semi-automatic controllers may be mounted 1 of 2 ways and is system specific. Mounting methods are "pipe mounted" or "flange mounted". For pipe mounted systems, verify the mounting accessories shown below and refer to steps 1 and 2A for installation. For flange mounted systems, refer to step 2B for installation.

Pipe mounting accessories (system specific):

- (2 pr.) *Mounting brackets and hardware
- (2) Controller supports
- (2) Isoplast bolts
- (2) Isoplast nuts

* Mounting brackets will vary based on the filter system being used. Brackets will fit waste pipe size of 4", 6", or 8" diameter, depending on waste pipe size.

Verify that all parts listed above were supplied before beginning installation. Replacement parts can be ordered through a Stark distributor.

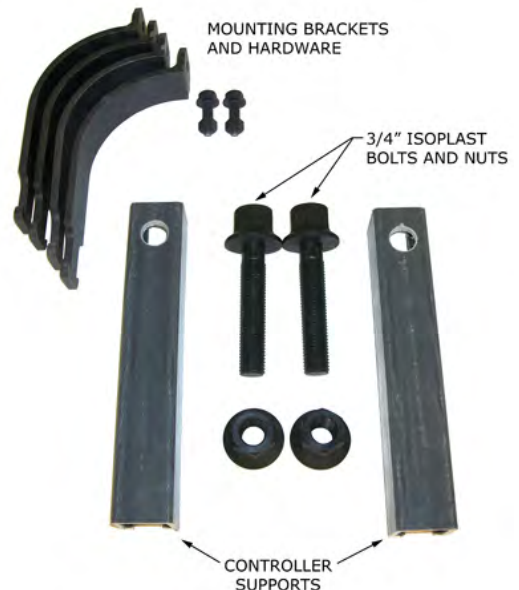

STEP 1: Controller Support Assembly

Attach controller supports to the gauge panel assembly using the $\frac{3}{4}$ " isoplast nuts and bolts. Attach so the channel side of the supports is away from the gauge panel. Tighten bolts, but do not over tighten, as this may crack the face of the gauge panel.

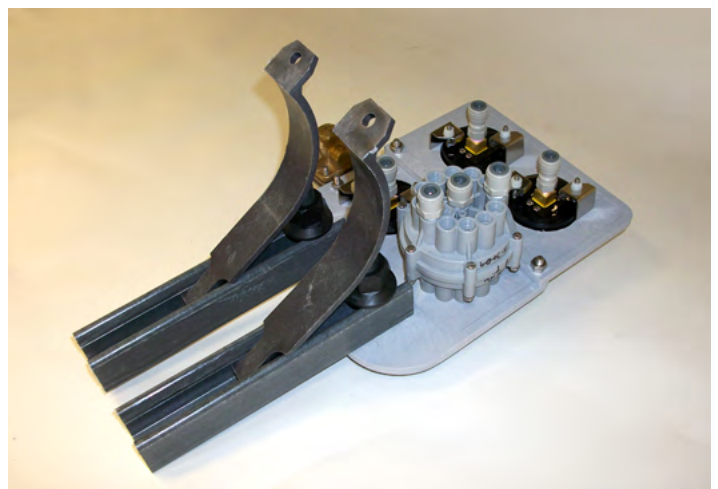

STEP 2A: Attach Gauge Panel to Pipe

Insert notched end of pipe clamps into the channel of the controller supports. Attach the gauge panel assembly to the waste extension (see picture). Slide remaining pipe clamps into the channels of the controller supports. Use the nuts and bolts supplied to tighten the clamps on to the pipe.



STEP 2B: Attach Gauge Panel to Flange

Attach the gauge panel assembly to flange (see picture). Insert isoplast bolts through the bottom holes of the gauge panel and top holes of the flange. Use the isoplast nuts to tighten in place.

**Please note that the setup shown is for a 6" flanged connection. The flange connection plate may be modified for use on a 4" or 8" flanged connection.



STEP 3: Installation of Controller Tubing

Connect length of tubing from supply source (water or compressed air) to the inlet side of the regulator. **Please note, the water source must be able to supply water at a pressure of 35 psi minimum.**

Connect length of tubing from the outlet side of the regulator to the inlet end of the check valve. Please note the direction of the flow arrow on the check valve. It should be pointing away from the regulator.

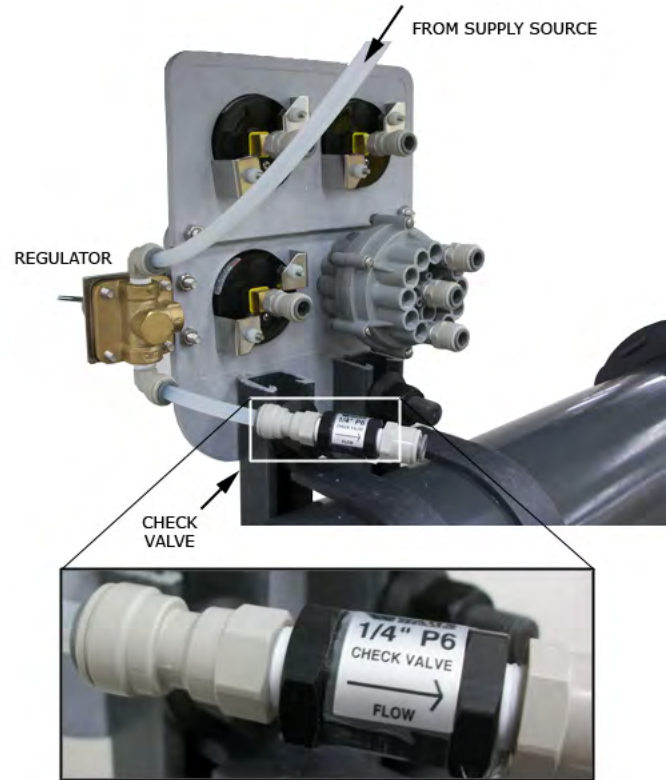

Connect length of tubing to open end of the check valve. Connect quick connect tee to end of tube.

Connect tubes from the quick connect tee to back of the gauge panel assembly as shown in picture. One end should be connected to the center fitting on the multiport valve. The other end should be connected to the multiport pressure gauge

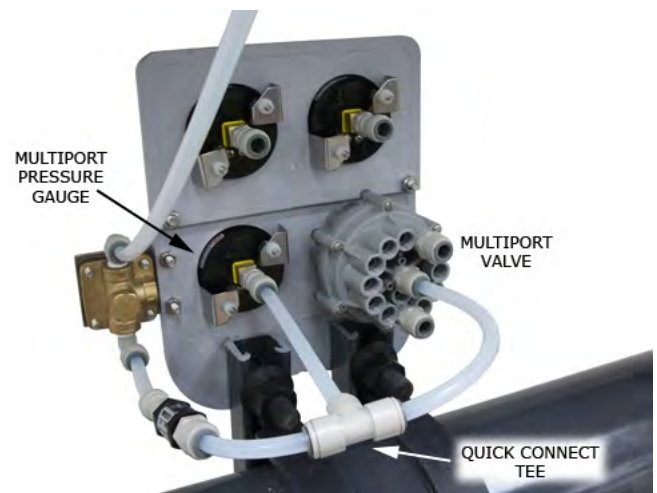

Drill and tap for 1/4" NPT hole on the influent and effluent pipes from the filter system (see schematic diagram in Appendix B). Install quick connect fittings into pipe. Be sure to use pipe thread sealant tape on the threads. Install 3/8" OD tube from fittings to rear of the gauge panel assembly. Connect tubes into correct gauge on the rear of the panel (see picture).

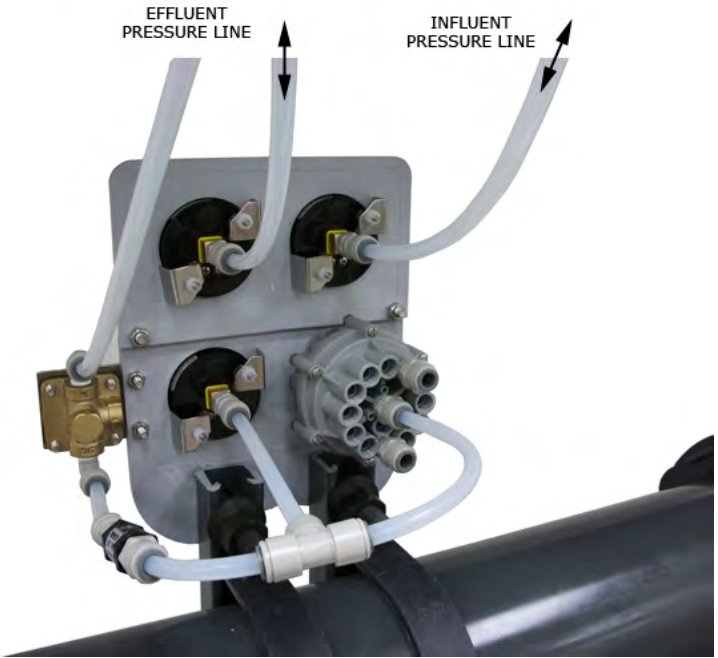

Connect lengths of tubing into the quick connect fittings on top of the valve cover. Join these two tubes with a quick connect tee as shown in the picture.

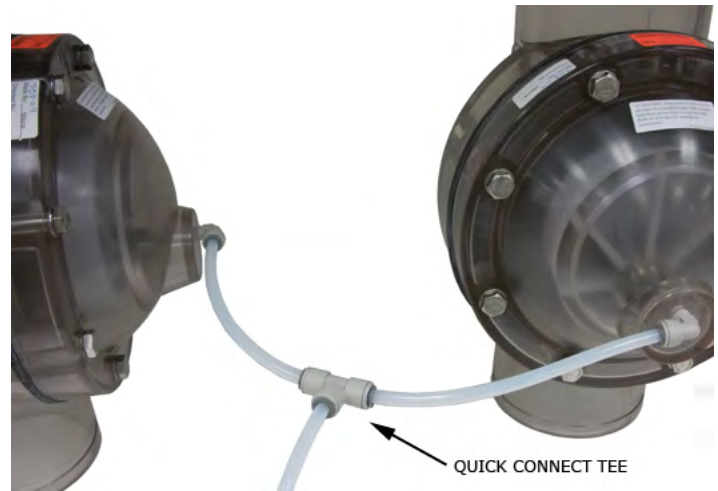

Connect a length of tube from the open end of the quick connect tee from the valves to the fitting on the back of the gauge panel assembly as shown in the picture. Connect tube from remaining quick connect fitting and connect to drain.

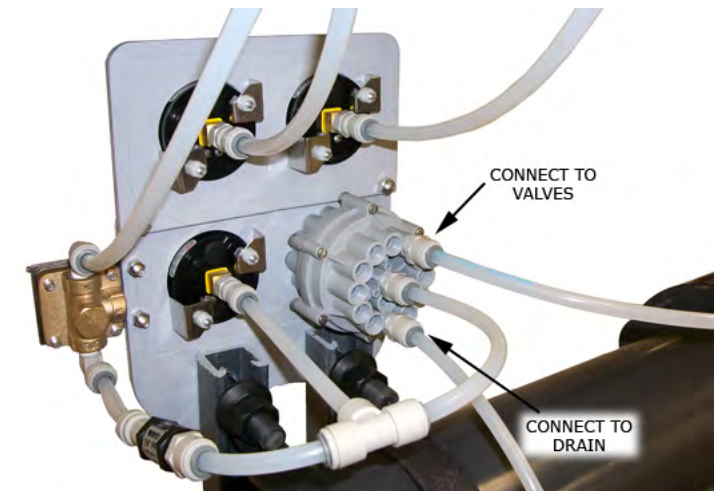

This completes the installation of the semi-automatic backwash controller for single tank systems. Please proceed to Section 2.6 for operating instructions.

2.5.2 Semi-Automatic Controller (CM200) – Dual Tank Installation

The dual tank semi-automatic controller kit consists of the following:

- (1) Controller gauge panel
- (3) 3/8" OD tube quick connect tees
- (3) 3/8" OD x 1/4" MNPT quick connect fittings
- (1) Check valve w/ fittings
- (1) And/Or Valve
- (100 ft) 3/8" OD polyethylene tube



Please refer to steps 1 & 2 of "Semi-Automatic Controller (CM200) – Single Tank Installation" for mounting of the gauge panel assembly to the filter system.

STEP 3: Installation of Controller Tubing

Connect length of tubing from supply source (water or compressed air) to the inlet side of the regulator. **Please note, the water source must be able to supply water at a pressure of 35 psi minimum.**

Connect length of tubing from the outlet side of the regulator to the inlet end of the check valve. Please note the direction of the flow arrow on the check valve. It should be pointing away from the regulator.

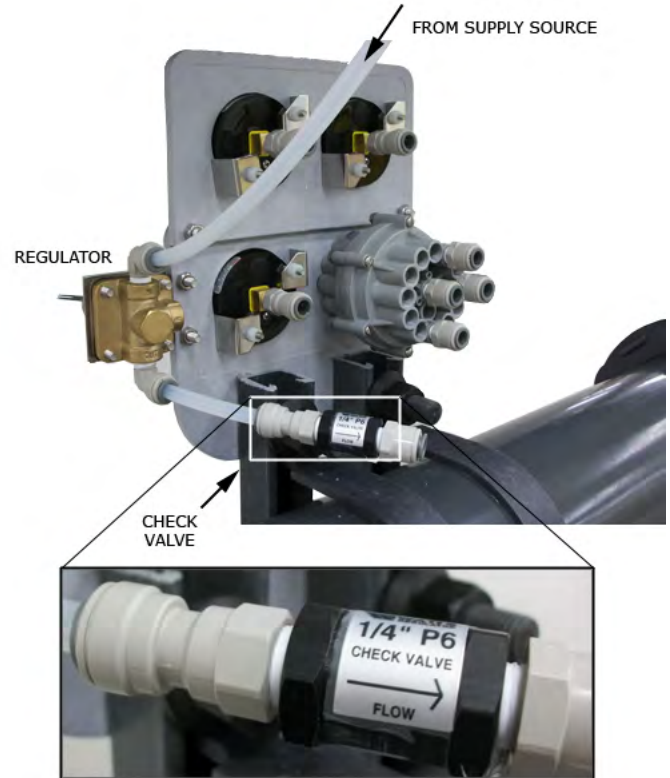

Connect length of tubing to open end of the check valve. Connect quick connect tee to end of tube.

Connect tubes from the quick connect tee to back of the gauge panel assembly as shown in picture. One end should be connected to the center fitting on the multiport valve. The other end should be connected to the multiport pressure gauge.

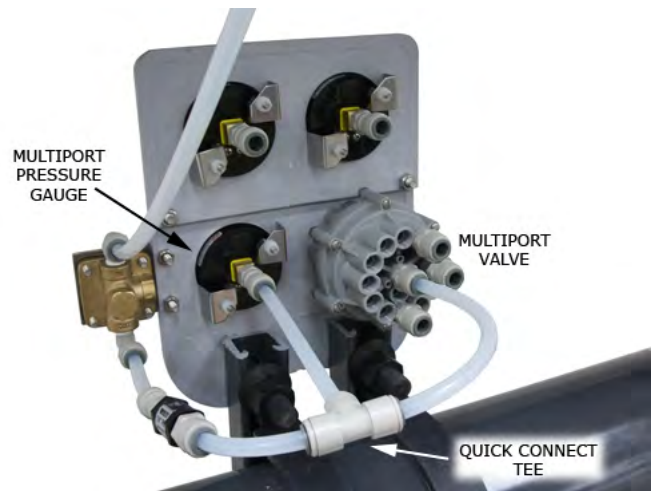

Drill and tap for ¼" NPT hole on the influent and effluent pipes from the filter system (see schematic diagram in Appendix B). Install quick connect fittings into pipe. Be sure to use pipe thread sealant tape on the threads. Install 3/8" OD tube from fittings to rear of the gauge panel assembly. Connect tubes into correct gauge on the rear of the panel (see picture).

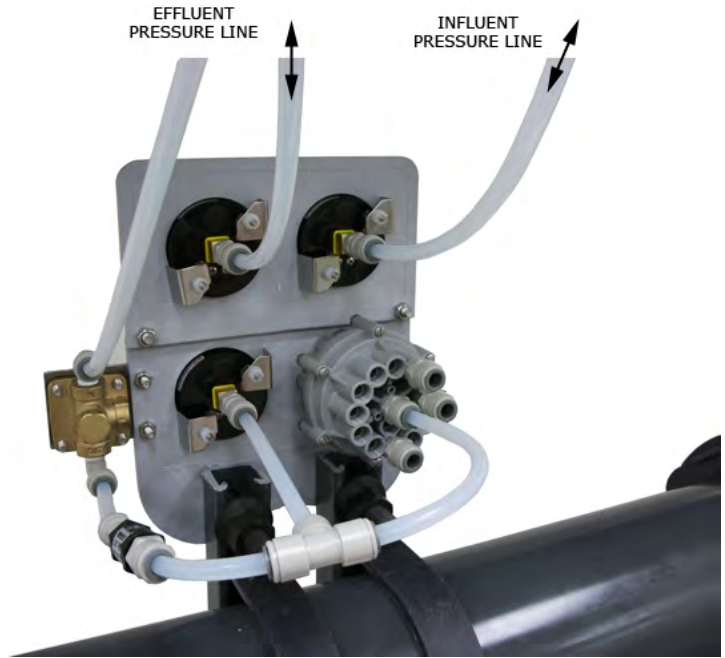

Assemble the And/Or assembly shown in the picture. Be sure to leave enough tubing to reach all of the necessary connections. Connect all tubes to their appropriate locations as explained in the picture.

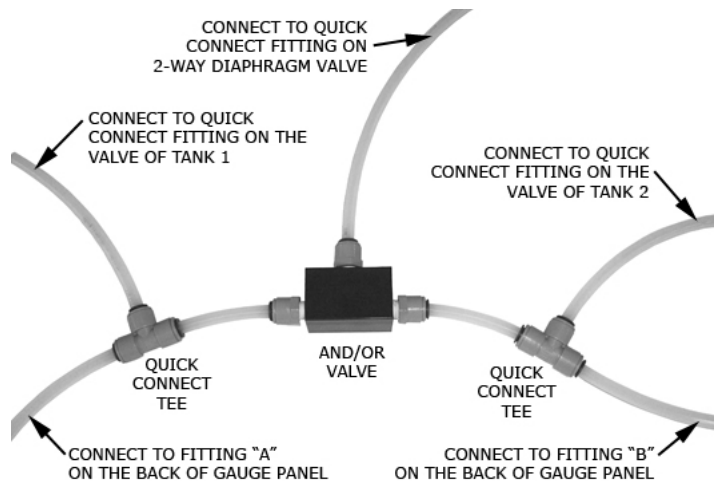

Connect tubes into respective fittings on gauge panel assembly. Connect a tube from remaining quick connect fitting and connect to drain.

This completes the installation of the semi-automatic backwash controller for dual tank systems. Please proceed to Section 2.6 for operating instructions.

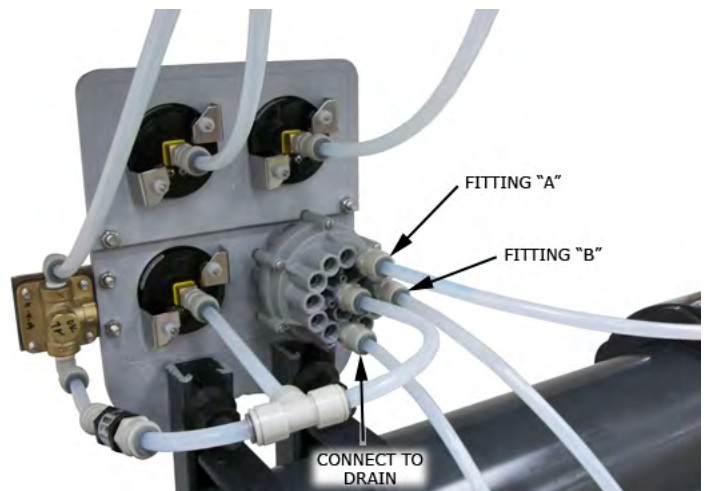

2.5.3 Semi-Automatic Controller (CM200) – Multiple Tank Installation

The multiple tank semi-automatic controller kit consists of the following:

- (1) Controller gauge panel
- (1) 3/8" OD tube quick connect tee
- (3) 3/8" OD x 1/4" MNPT quick connect fittings
- (1) Check valve w/ fittings
- (200 ft) 3/8" OD polyethylene tube



Please refer to steps 1 & 2 of "Semi-Automatic Controller (CM200) – Single Tank Installation" for mounting of the gauge panel assembly to the filter system.

STEP 3: Installation of Controller Tubing

Connect length of tubing from supply source (water or compressed air) to the inlet side of the regulator. **Please note, the water source must be able to supply water at a pressure of 35 psi minimum.**

Connect length of tubing from the outlet side of the regulator to the inlet end of the check valve. Please note the direction of the flow arrow on the check valve. It should be pointing away from the regulator.

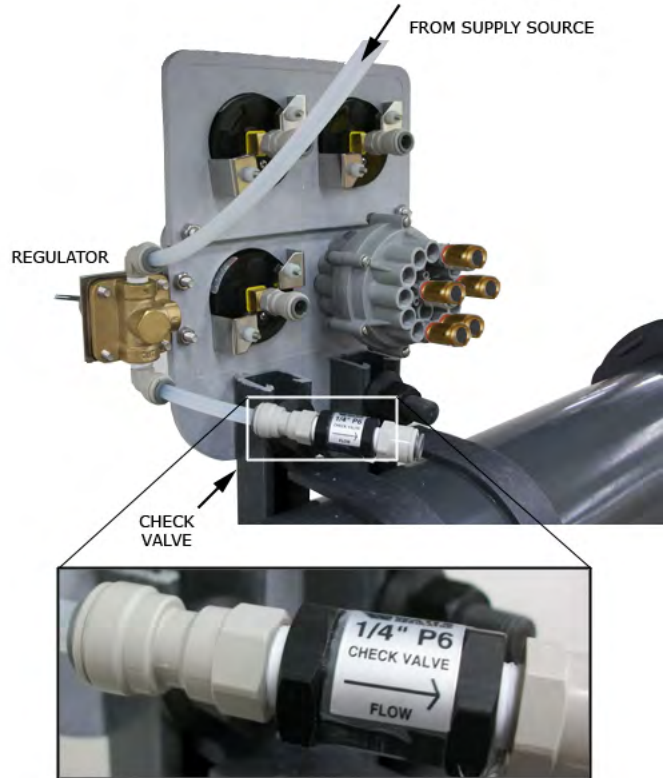

Connect length of tubing to open end of the check valve. Connect quick connect tee to end of tube.

Connect tubes from the quick connect tee to back of the gauge panel assembly as shown in picture. One end should be connected to the center fitting on the multiport valve. The other end should be connected to the multiport pressure gauge.

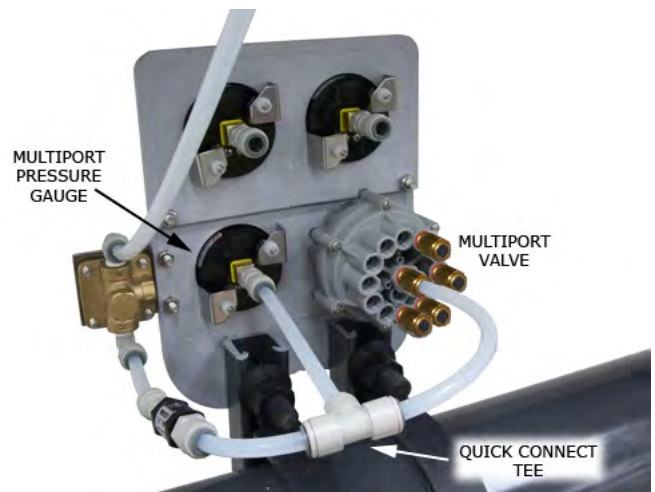

Drill and tap for 1/4" NPT hole on the influent and effluent pipes from the filter system (see schematic diagram in Appendix B). Install quick connect fittings into pipe. Be sure to use pipe thread sealant tape on the threads. Install 3/8" OD tube from fittings to rear of the gauge panel assembly. Connect tubes into correct gauge on the rear of the panel (see picture).

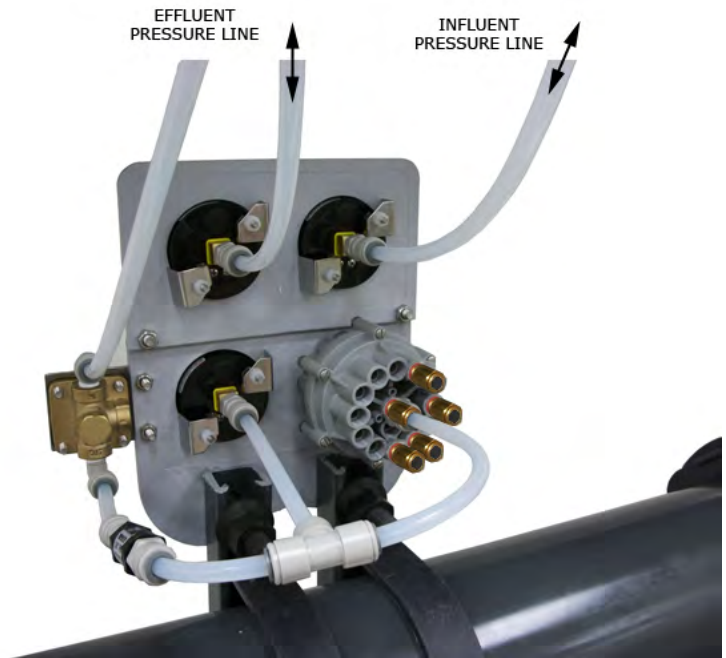

Connect a length of tubing into the quick connect fitting on top of the valve cover for tank 1. Repeat this process for each tank valve.



Connect each tube from the tank valves to the respective fitting on the back of the gauge panel assembly as shown in the picture (up to 10 tanks). Connect tube from remaining quick connect fitting and connect to drain.

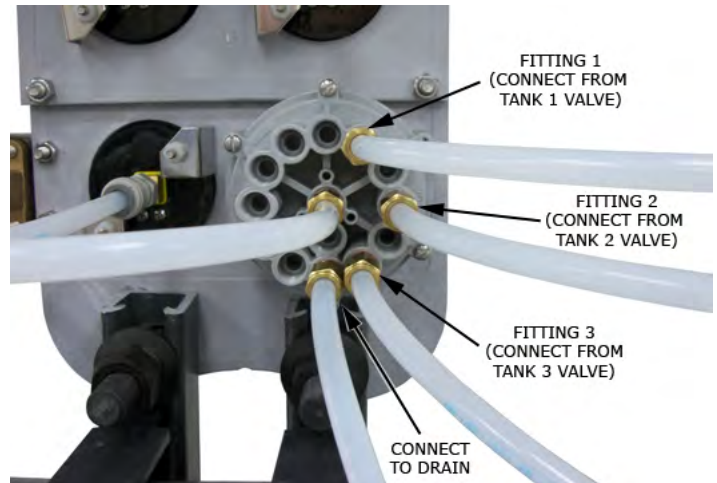

This completes the installation of the semi-automatic backwash controller for multiple tank systems. Please proceed to Section 2.6 for operating instructions

2.5.4 Automatic Controller (CA100) - Single Tank Installation

The single tank automatic controller kit consists of the following:

- (1) Automatic controller enclosure
- (1) Multiport valve enclosure
- (4) 3/8" OD tube quick connect tees
- (3) 3/8" OD x 1/4" MNPT quick connect fittings
- (1) Check valve w/ fittings
- (100 ft) 3/8" OD polyethylene tube
- (4pr.) Mounting brackets and hardware
- (1) Owner's/Operator's manual for automatic controller



Verify that all parts listed above were supplied before beginning installation. Replacement parts can be ordered through a Stark distributor.

STEP 1: Attach Controller/Multiport Enclosures to Piping

Insert notched end of pipe clamps into the channel of the enclosure supports. Attach the enclosure assemblies to the waste extension (see picture). Slide remaining pipe clamps into the channels of the enclosure supports. Use the nuts and bolts supplied to tighten the clamps on to the pipe.

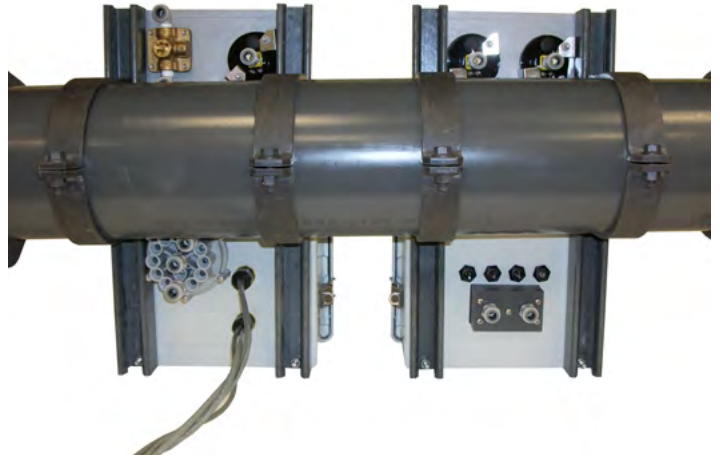

STEP 2: Installation of Controller Tubing

Insert a length of 3/8" tube into top fitting on the regulator (see picture). Connect other end of this tube to your supply source (water or compressed air). An extra 3/8" x 1/4" MNPT fitting has been provided for connection. **Please note, the water source must be able to supply water at a pressure of 35 psi minimum.** Connect the check valve to the other fitting from the regulator with a small length of tubing. Make sure that the arrow on the check valve is pointed away from the regulator. From the other end of the check valve, connect a length of tube and attach a quick connect tee fitting (see picture).

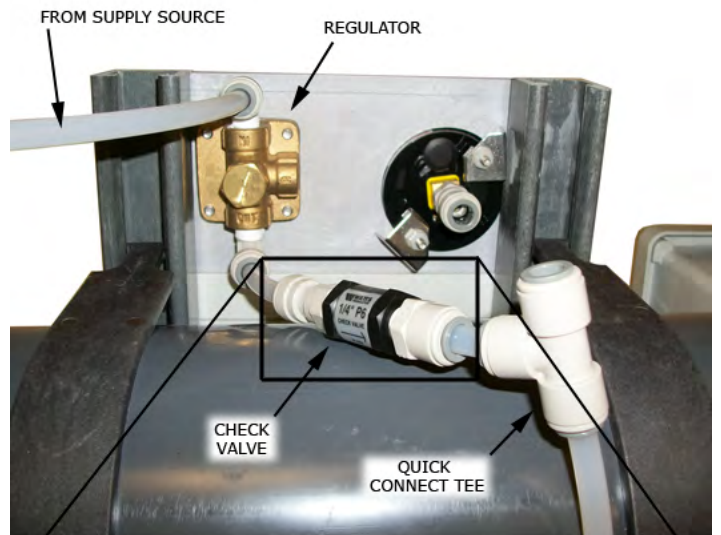

Connect tubes to each side of the quick connect tee. Connect one tube to the multiport pressure gauge and the other to the center fitting on the multiport valve (see picture).

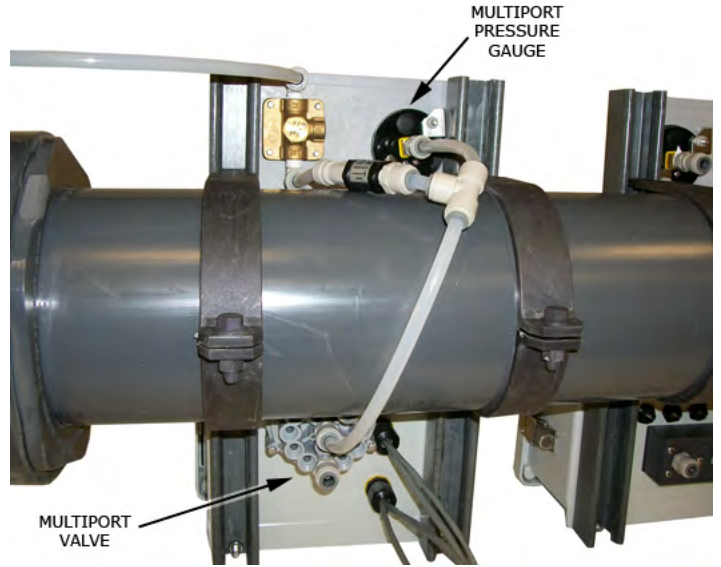

Drill and tap for 1/4" NPT hole on the influent and effluent pipes from the filter system (see schematic diagram in Appendix B). Install quick connect fittings into holes. Be sure to use pipe thread sealant tape on the threads. Install into each fitting a length of 3/8" OD tubing. Connect a quick connect tee on to the other end of each tube. Connect two smaller pieces of tubing into each end of the tee and connect to the rear of the automatic controller enclosure as shown.

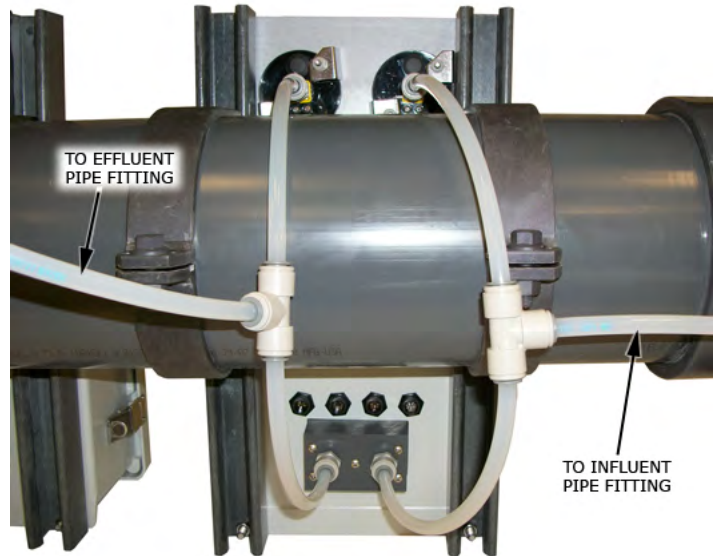

Connect lengths of tubing into the quick connect fittings on top of the valve cover. Join the two tubes with a quick connect tee as shown in the picture.

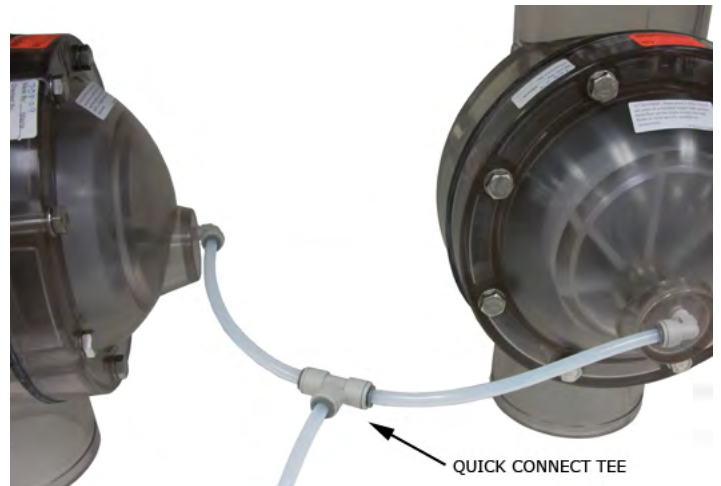

Connect a length of tube from the open end of the quick connect tee from the valves to the fitting on the back of the multiport valve enclosure as shown in the picture. Connect tube from remaining quick connect fitting and connect to drain.

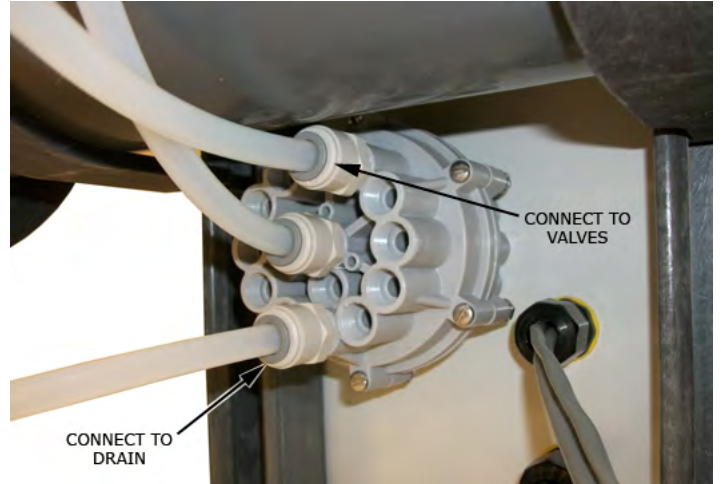

Connect the four wires from the rear of the multiport valve enclosure to the rear of the automatic controller enclosure. Each wire has a different style pin connector and can only connect to one of the sockets on the back of the automatic controller enclosure.



This completes the installation of the automatic backwash controller for single tank systems. Please see Owner's/Operator's Manual for automatic controller set up and operation.

2.5.5 Automatic Controller (CA100) – Dual Tank Installation

The dual tank automatic controller kit consists of the following:

- (1) Automatic controller enclosure
- (1) Multiport valve enclosure
- (5) 3/8" OD tube quick connect tees
- (3) 3/8" OD x 1/4" MNPT quick connect fittings
- (1) And/Or Valve
- (1) Check valve w/ fittings
- (100 ft) 3/8" OD polyethylene tube
- (4pr.) Mounting brackets and hardware
- (1) Owner's/Operator's manual for automatic controller



Verify that all parts listed above were supplied before beginning installation. Replacement parts can be ordered through a Stark distributor.

STEP 1: Attach Controller/Multiport Enclosures to Piping

Insert notched end of pipe clamps into the channel of the enclosure supports. Attach the enclosure assemblies to the waste extension (see picture). Slide remaining pipe clamps into the channels of the enclosure supports. Use the nuts and bolts supplied to tighten the clamps on to the pipe.

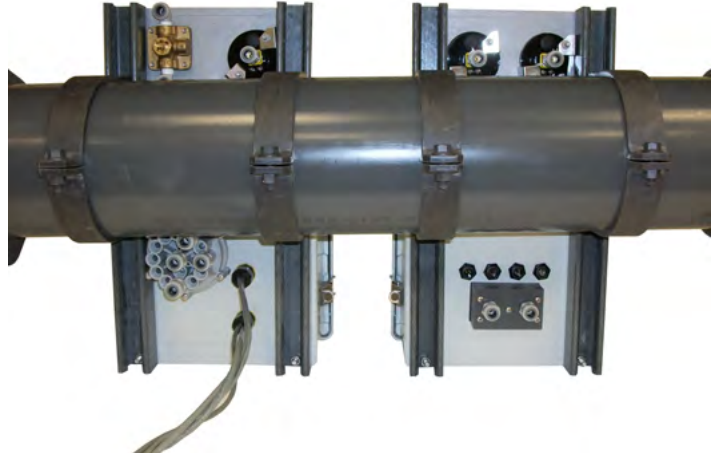

STEP 2: Installation of Controller Tubing

Insert a length of 3/8" tube into top fitting on the regulator (see picture). Connect other end of this tube to your supply source (water or compressed air). An extra 3/8" x 1/4" MNPT fitting has been provided for connection. **Please note, the water source must be able to supply water at a pressure of 35 psi minimum.** Connect the check valve to the other fitting from the regulator with a small length of tubing. Make sure that the arrow on the check valve is pointed away from the regulator. From the other end of the check valve, connect a length of tube and attach a quick connect tee fitting (see picture).

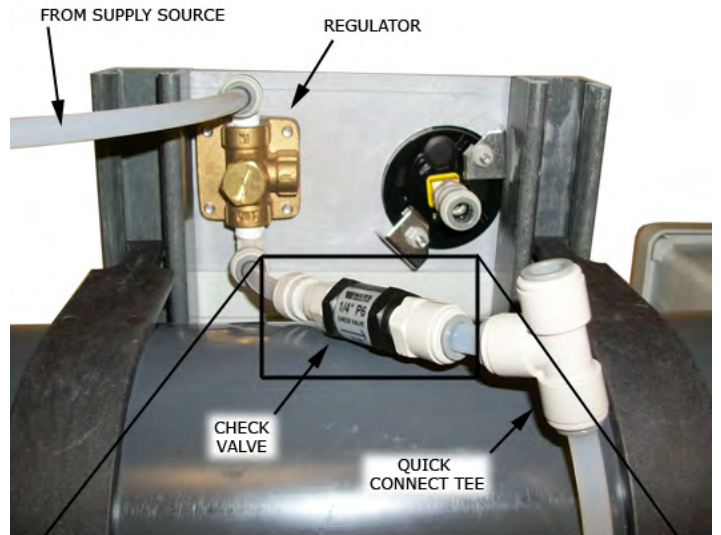

Connect tubes to each side of the quick connect tee. Connect one tube to the multiport pressure gauge and the other to the center fitting on the multiport valve (see picture).

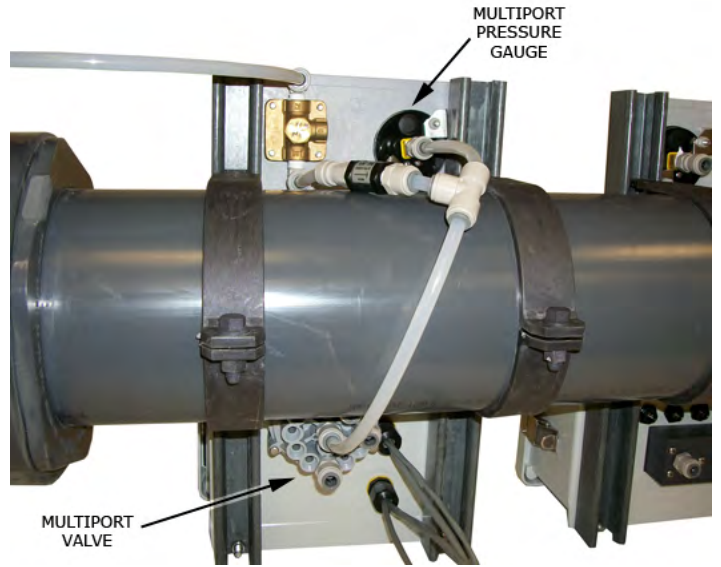

Drill and tap for 1/4" NPT hole on the influent and effluent pipes from the filter system (see schematic diagram in Appendix B). Install quick connect fittings into holes. **Be sure to use pipe thread sealant tape on the threads.** Install into each fitting a length of 3/8" OD tubing. Connect a quick connect tee on to the other end of each tube. Connect two smaller pieces of tubing into each end of the tee and connect to the rear of the automatic controller enclosure as shown.

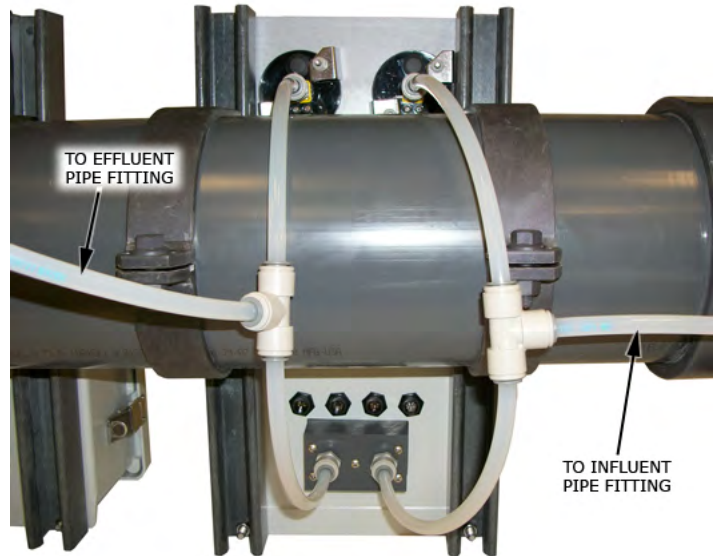

Assemble the And/Or assembly shown in the picture. Be sure to leave enough tubing to reach all of the necessary connections. Connect all tubes to their appropriate locations as explained in the picture.

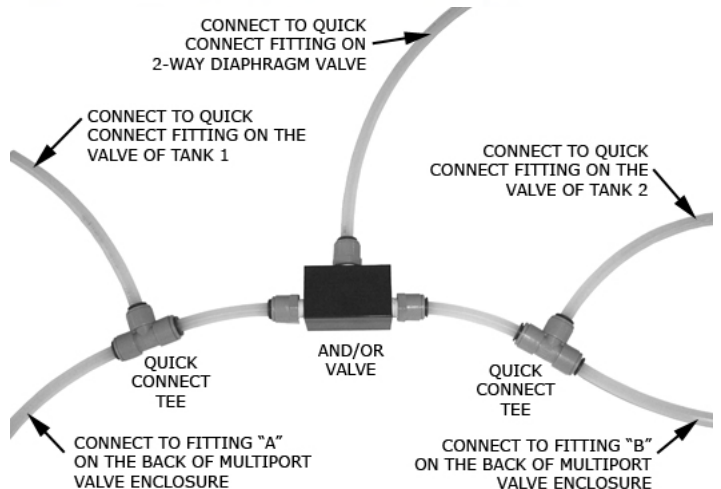

Connect tubes into respective fittings on the back of the multiport valve enclosure. Connect a tube from remaining quick connect fitting and connect to drain.

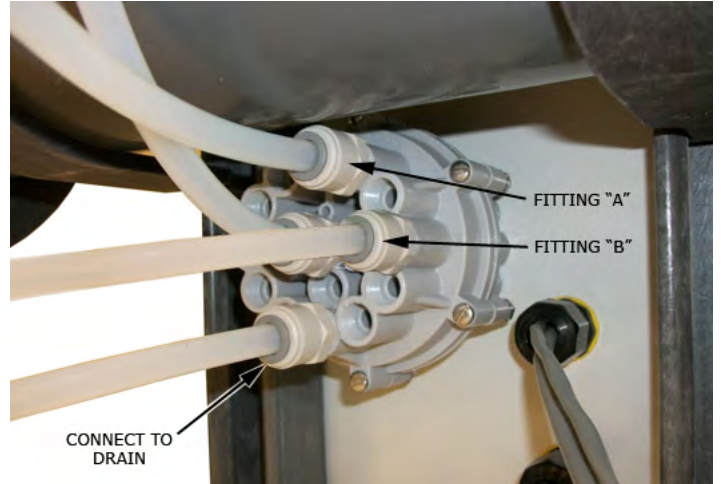

Connect the four wires from the rear of the multiport valve enclosure to the rear of the automatic controller enclosure. Each wire has a different style pin connector and can only connect to one of the sockets on the back of the automatic controller enclosure.



This completes the installation of the automatic backwash controller for dual tank systems. Please see Owner's/Operator's Manual for automatic controller set up and operation.

2.5.6 Automatic Controller (CA100) – Multiple Tank Installation

The multiple tank automatic controller kit consists of the following:

- (1) Automatic controller enclosure
- (1) Multiport valve enclosure
- (3) 3/8" OD tube quick connect tees
- (3) 3/8" OD x 1/4" MNPT quick connect fittings
- (1) Check valve w/ fittings
- (200 ft) 3/8" OD polyethylene tube
- (4pr.) Mounting brackets and hardware
- (1) Owner's/Operator's manual for automatic controller



Verify that all parts listed above were supplied before beginning installation. Replacement parts can be ordered through a Stark distributor.

STEP 1: Attach Controller/Multiport Enclosures to Piping

Insert notched end of pipe clamps into the channel of the enclosure supports. Attach the enclosure assemblies to the waste extension (see picture). Slide remaining pipe clamps into the channels of the enclosure supports. Use the nuts and bolts supplied to tighten the clamps on to the pipe.

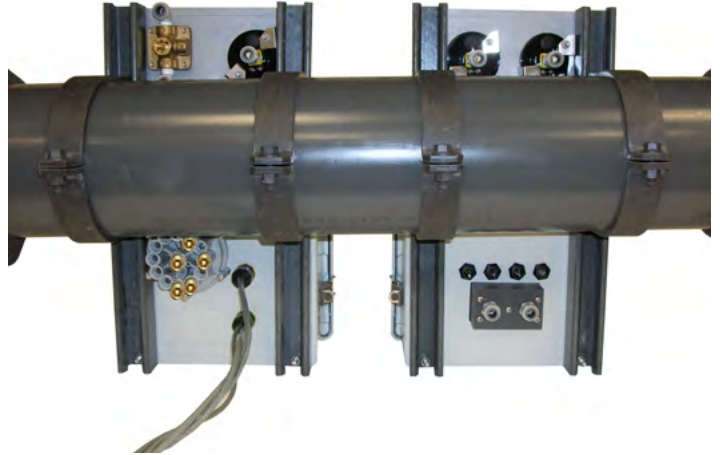

STEP 2: Installation of Controller Tubing

Insert a length of 3/8" tube into top fitting on the regulator (see picture). Connect other end of this tube to your supply source (water or compressed air). An extra 3/8" x 1/4" MNPT fitting has been provided for connection. **Please note, the water source must be able to supply water at a pressure of 35 psi minimum.** Connect the check valve to the other fitting from the regulator with a small length of tubing. Make sure that the arrow on the check valve is pointed away from the regulator. From the other end of the check valve, connect a length of tube and attach a quick connect tee fitting (see picture).

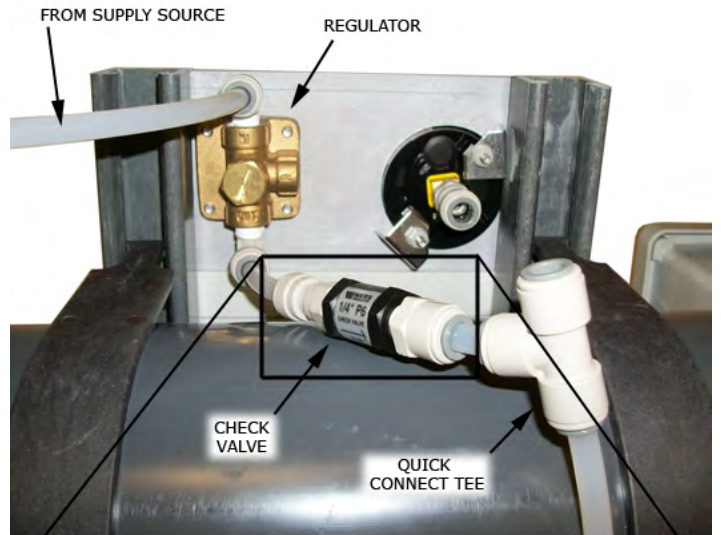

Connect tubes to each side of the quick connect tee. Connect one tube to the multiport pressure gauge and the other to the center fitting on the multiport valve (see picture).

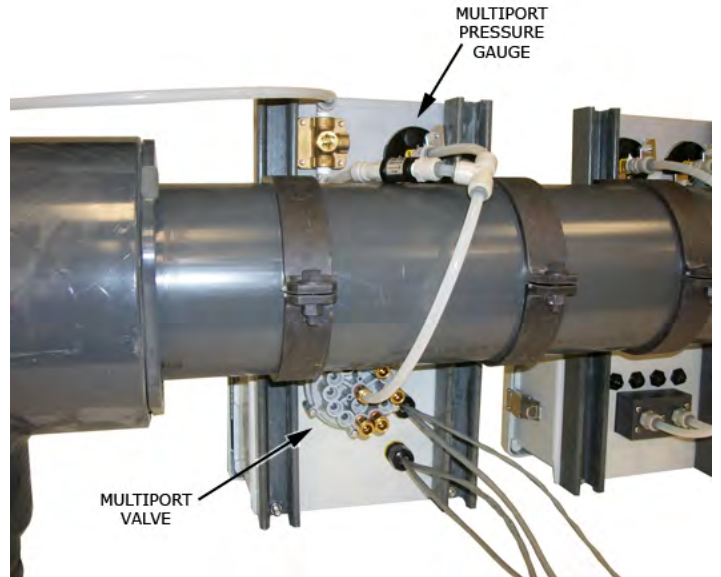

Drill and tap for 1/4" NPT hole on the influent and effluent pipes from the filter system (see schematic diagram in Appendix B). Install quick connect fittings into holes. **Be sure to use pipe thread sealant tape on the threads.** Install into each fitting a length of 3/8" OD tubing. Connect a quick connect tee on to the other end of each tube. Connect two smaller pieces of tubing into each end of the tee and connect to the rear of the automatic controller enclosure as shown.

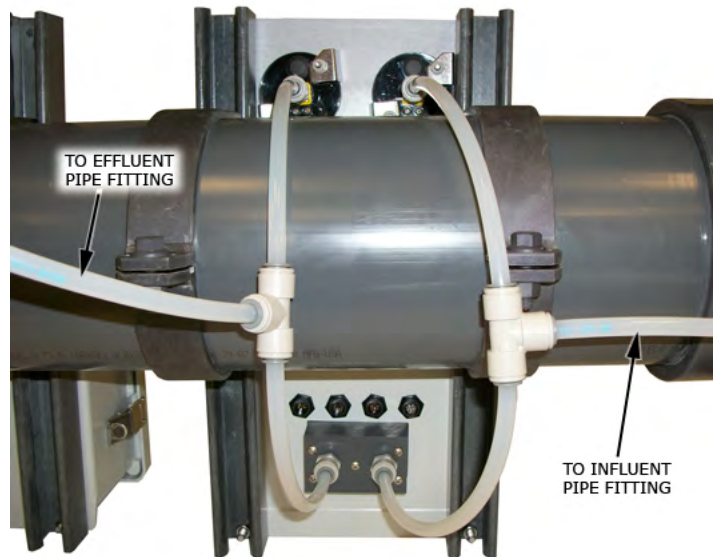

Connect a length of tubing into the quick connect fittings on top of the valve cover for tank 1. Repeat this process for each tank valve.



Connect each tube from the tank valves to the respective fitting on the back of the gauge panel assembly as shown in the picture (up to 10 tanks). Connect tube from remaining quick connect fitting and connect to drain.

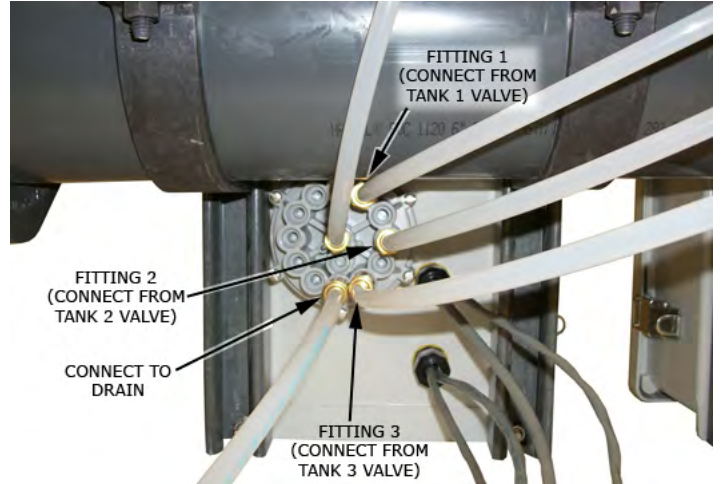

Connect the four wires from the rear of the multiport valve enclosure to the rear of the automatic controller enclosure. Each wire has a different style pin connector and can only connect to one of the sockets on the back of the automatic controller enclosure.



This completes the installation of the automatic backwash controller for multiple tank systems. Please see Owner's/Operator's Manual for automatic controller set up and operation.

2.5.7 Backwash Controller (CS400) - Single Tank Installation

The single tank backwash controller kit (CS400) consists of the following:

- (1) CS400 backwash controller enclosure
- (2) 3/8" OD tube quick connect tees
- (3) 3/8" OD x 1/4" MNPT quick connect fittings
- (1) Check valve w/ fittings
- (100 ft) 3/8" OD polyethylene tube (2pr.) Mounting brackets and hardware
- (1) Owner's/Operator's manual for CS400 backwash controller



Verify that all parts listed above were supplied before beginning installation. Replacement parts can be ordered through a Stark distributor.

STEP 1: Attach Controller/Multiport Enclosures to Piping

Insert notched end of pipe clamps into the channel of the backwash controller enclosure support. Attach the backwasher controller enclosure to the waste extension (see picture). Slide remaining pipe clamps into the channels of the enclosure support. Use the nuts and bolts supplied to tighten the clamps on to the pipe.



STEP 2: Installation of Controller Tubing

Insert a length of 3/8" tube into top fitting on the regulator (see picture). Connect other end of this tube to your supply source (water or compressed air). An extra 3/8" x 1/4" MNPT fitting has been provided for connection. **Please note, the water source must be able to supply water at a pressure of 35 psi minimum.** Connect the check valve to the other fitting from the regulator with a small length of tubing. Make sure that the arrow on the check valve is pointed away from the regulator. From the other end of the check valve, connect a length of tube and attach a quick connect tee fitting (see picture).

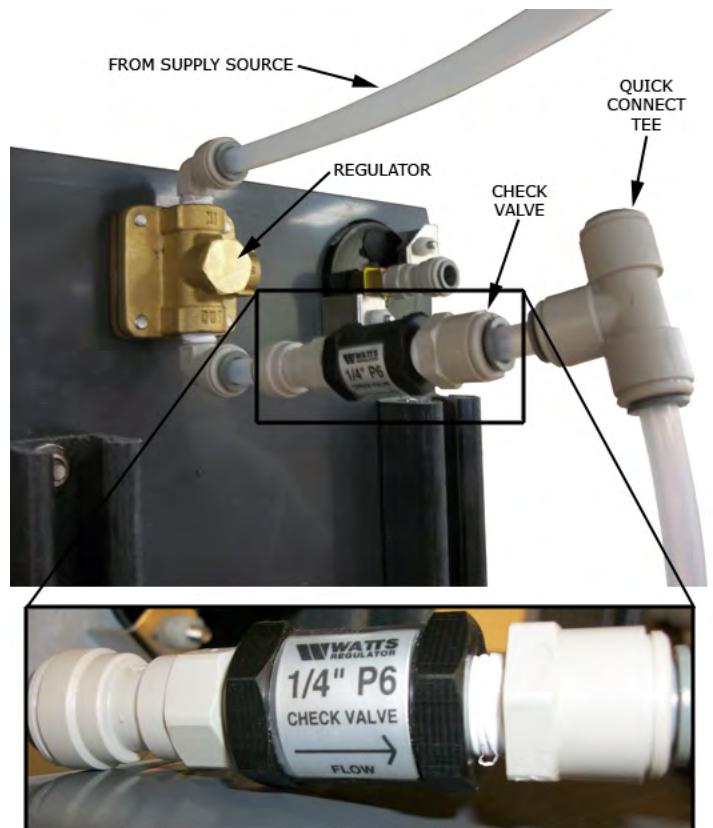

Connect tubes to each side of the quick connect tee. Connect one tube to the multiport pressure gauge and the other to the center fitting on the multiport valve (see picture).

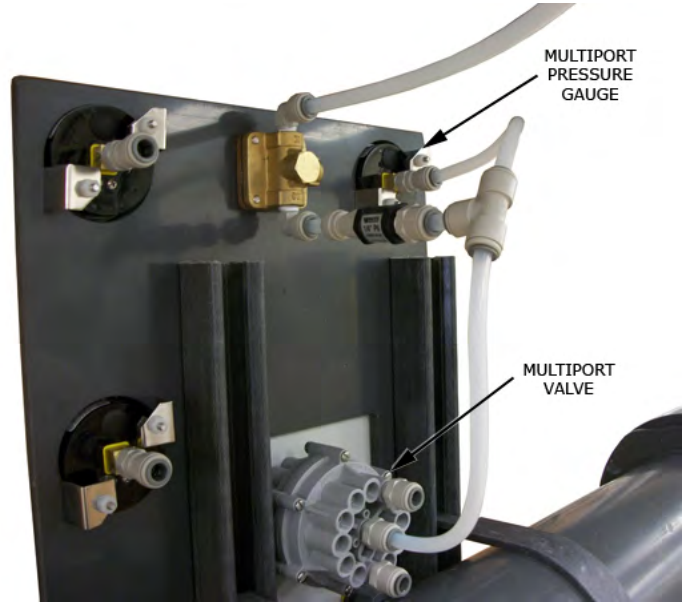

Drill and tap for 1/4" NPT hole on the influent and effluent pipes from the filter system (see schematic diagram in Appendix B). Install quick connect fittings into pipe. Be sure to use pipe thread sealant tape on the threads. Install 3/8" OD tube from fittings to rear of the gauge panel assembly. Connect tubes into correct gauge on the rear of the panel (see picture).

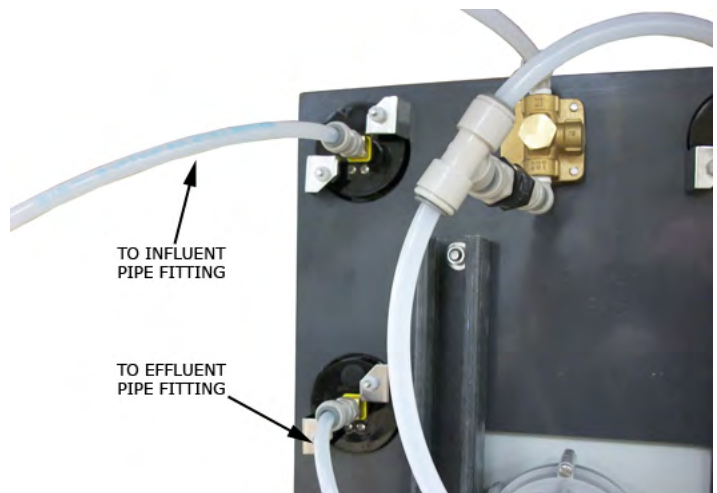

Connect lengths of tubing into the quick connect fittings on top of the valve cover. Join the two tubes with a quick connect tee as shown in the picture.

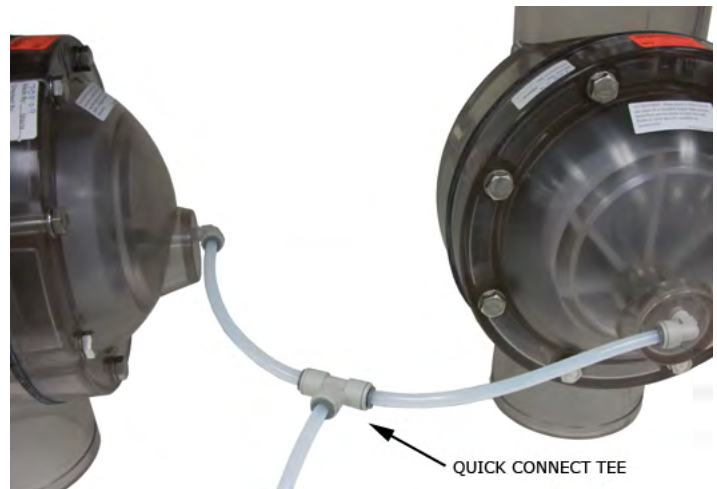

Connect a length of tube from the open end of the quick connect tee from the valves to the fitting on the back of the backwash controller enclosure as shown in the picture. Connect tube from remaining quick connect fitting and connect to drain.

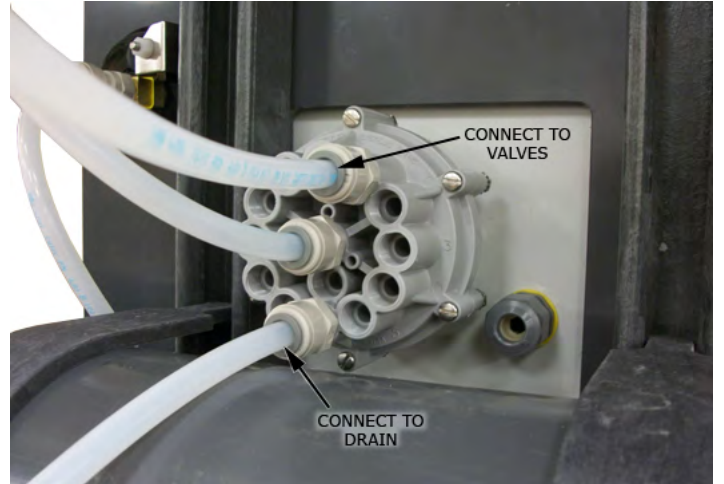

This completes the installation of the backwash controller (CS400) for single tank systems. Please see Owner's/Operator's Manual for backwash controller set up and operation.

2.5.8 Backwash Controller (CS400) - Dual Tank Installation

The dual tank backwash controller kit (CS400) consists of the following:

- (1) CS400 backwash controller enclosure
- (3) 3/8" OD tube quick connect tees
- (3) 3/8" OD x 1/4" MNPT quick connect fittings
- (1) Check valve w/ fittings
- (1) And/Or Valve
- (100 ft) 3/8" OD polyethylene tube (2pr.) Mounting brackets and hardware
- (1) Owner's/Operator's manual for CS400 backwash controller



Verify that all parts listed above were supplied before beginning installation. Replacement parts can be ordered through a Stark distributor.

STEP 1: Attach Controller/Multiport Enclosures to Piping

Insert notched end of pipe clamps into the channel of the backwash controller enclosure support. Attach the backwasher controller enclosure to the waste extension (see picture). Slide remaining pipe clamps into the channels of the enclosure support. Use the nuts and bolts supplied to tighten the clamps on to the pipe.



STEP 2: Installation of Controller Tubing

Insert a length of 3/8" tube into top fitting on the regulator (see picture). Connect other end of this tube to your supply source (water or compressed air). An extra 3/8" x 1/4" MNPT fitting has been provided for connection. **Please note, the water source must be able to supply water at a pressure of 35 psi minimum.** Connect the check valve to the other fitting from the regulator with a small length of tubing. Make sure that the arrow on the check valve is pointed away from the regulator. From the other end of the check valve, connect a length of tube and attach a quick connect tee fitting (see picture).

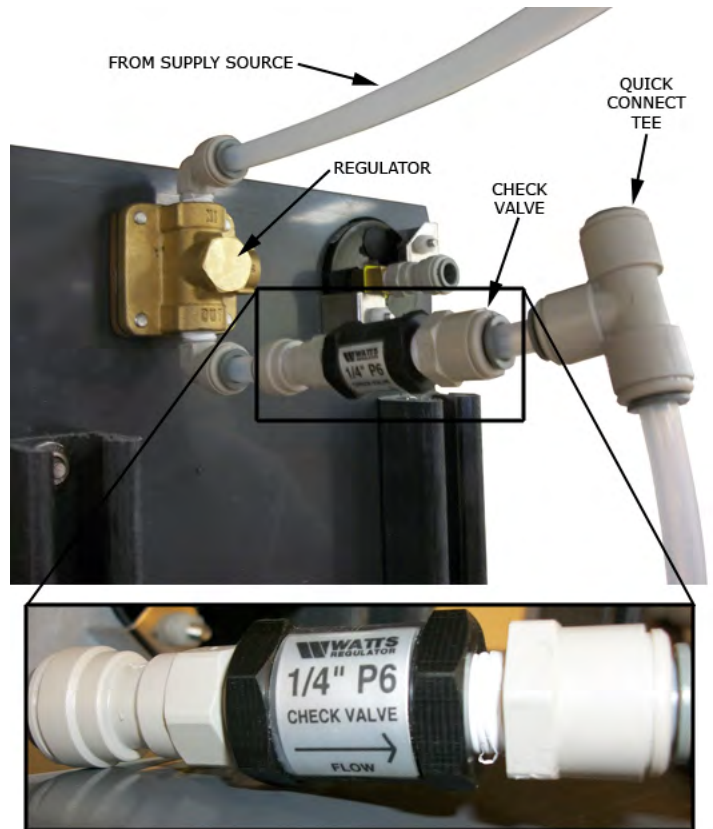

Connect tubes to each side of the quick connect tee. Connect one tube to the multiport pressure gauge and the other to the center fitting on the multiport valve (see picture).

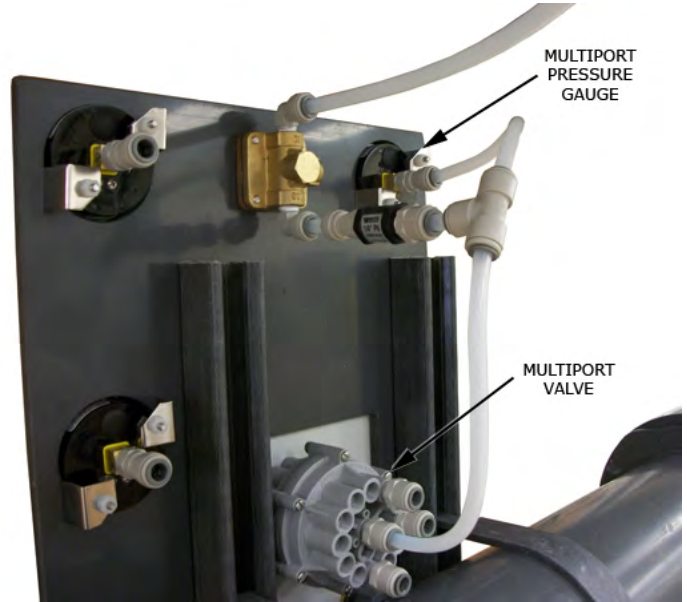

Drill and tap for 1/4" NPT hole on the influent and effluent pipes from the filter system (see schematic diagram in Appendix B). Install quick connect fittings into pipe. **Be sure to use pipe thread sealant tape on the threads.** Install 3/8" OD tube from fittings to rear of the gauge panel assembly. Connect tubes into correct gauge on the rear of the panel (see picture).

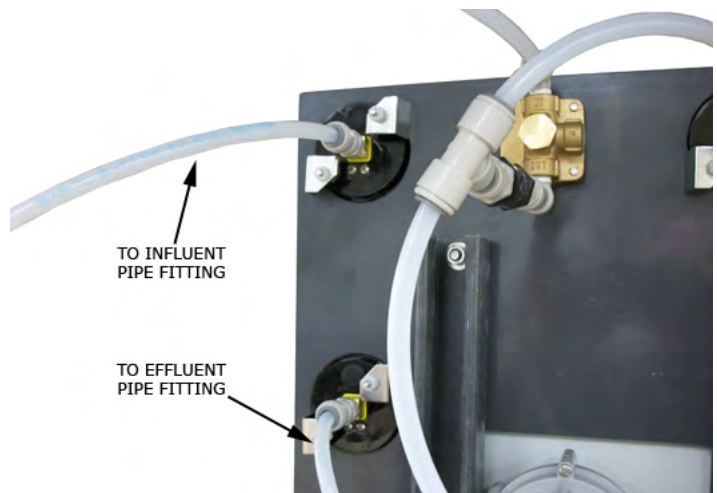

Assemble the And/Or assembly shown in the picture. Be sure to leave enough tubing to reach all of the necessary connections. Connect all tubes to their appropriate locations as explained in the picture.

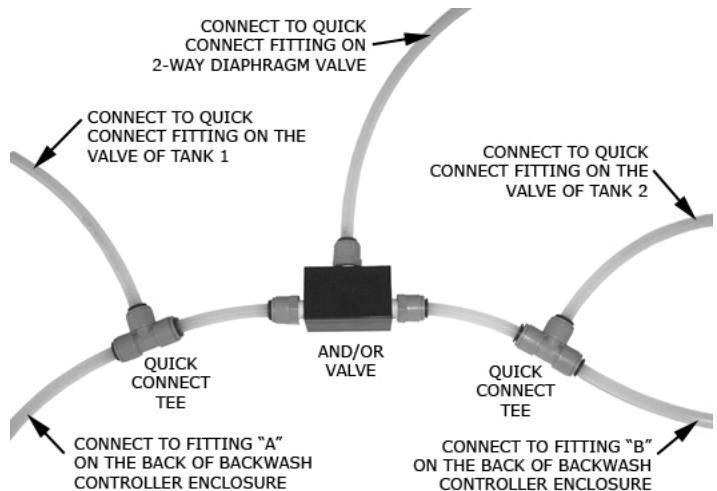

Connect tubes into respective fittings on the back of the backwash controller enclosure. Connect a tube from remaining quick connect fitting and connect to drain.

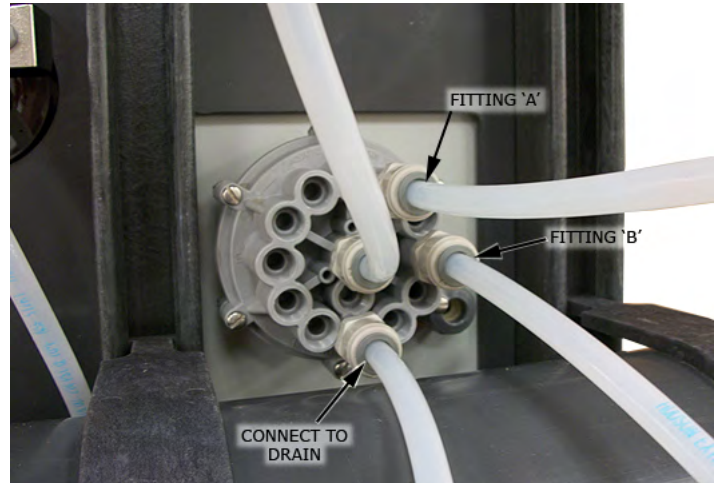

This completes the installation of the backwash controller (CS400) for dual tank systems. Please see Owner's/Operator's Manual for backwash controller set up and operation.

2.5.9 Backwash Controller (CS400) - Multiple Tank Installation

The multiple tank backwash controller kit (CS400) consists of the following:

- (1) CS400 backwash controller enclosure
- (1) 3/8" OD tube quick connect tee
- (3) 3/8" OD x 1/4" MNPT quick connect fittings
- (1) Check valve w/ fittings
- (200 ft) 3/8" OD polyethylene tube
- (2pr.) Mounting brackets and hardware
- (1) Owner's/Operator's manual for CS400 backwash controller



Verify that all parts listed above were supplied before beginning installation. Replacement parts can be ordered through a Stark distributor.

STEP 1: Attach Controller/Multiport Enclosures to Piping

Insert notched end of pipe clamps into the channel of the backwash controller enclosure support. Attach the backwasher controller enclosure to the waste extension (see picture). Slide remaining pipe clamps into the channels of the enclosure support. Use the nuts and bolts supplied to tighten the clamps on to the pipe.



STEP 2: Installation of Controller Tubing

Insert a length of 3/8" tube into top fitting on the regulator (see picture). Connect other end of this tube to your supply source (water or compressed air). An extra 3/8" x 1/4" MNPT fitting has been provided for connection. **Please note, the water source must be able to supply water at a pressure of 35 psi minimum.** Connect the check valve to the other fitting from the regulator with a small length of tubing. Make sure that the arrow on the check valve is pointed away from the regulator. From the other end of the check valve, connect a length of tube and attach a quick connect tee fitting (see picture).

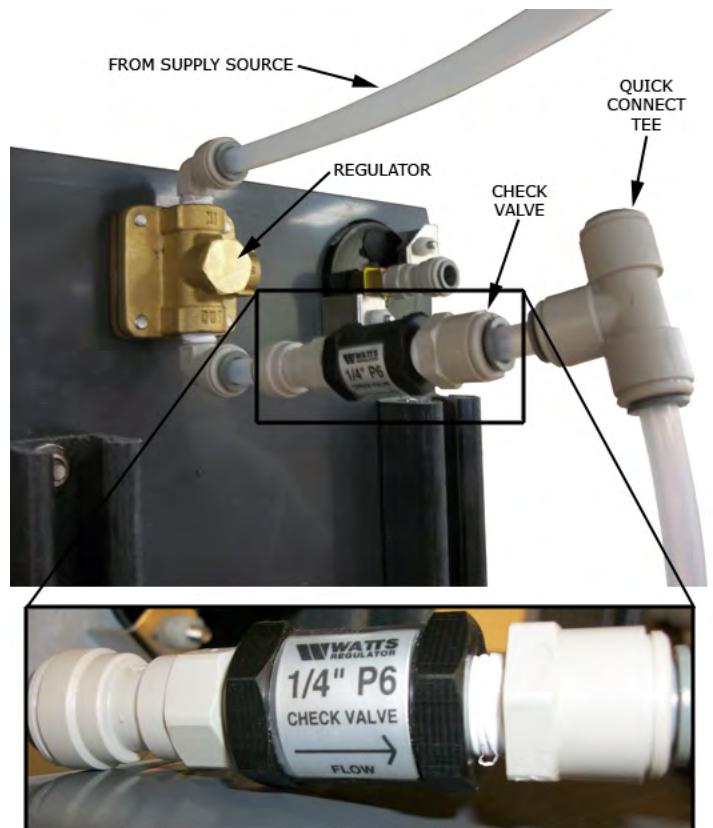

Connect tubes to each side of the quick connect tee. Connect one tube to the multiport pressure gauge and the other to the center fitting on the multiport valve (see picture).

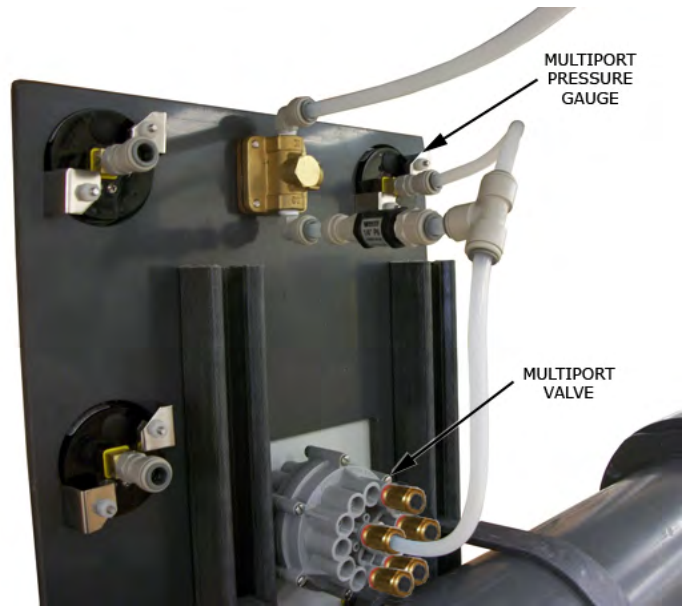

Drill and tap for 1/4" NPT hole on the influent and effluent pipes from the filter system (see schematic diagram in Appendix B). Install quick connect fittings into pipe. **Be sure to use pipe thread sealant tape on the threads.** Install 3/8" OD tube from fittings to rear of the gauge panel assembly. Connect tubes into correct gauge on the rear of the panel (see picture).

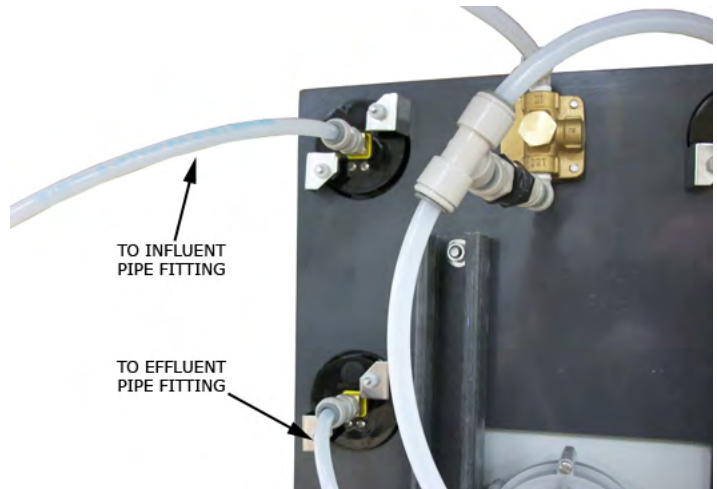

Connect a length of tubing into the quick connect fittings on top of the valve cover for tank 1. Repeat this process for each tank valve.



Connect each tube from the tank valves to the respective fitting on the back of the gauge panel assembly as shown in the picture (up to 6 tanks). Connect tube from remaining quick connect fitting and connect to drain.

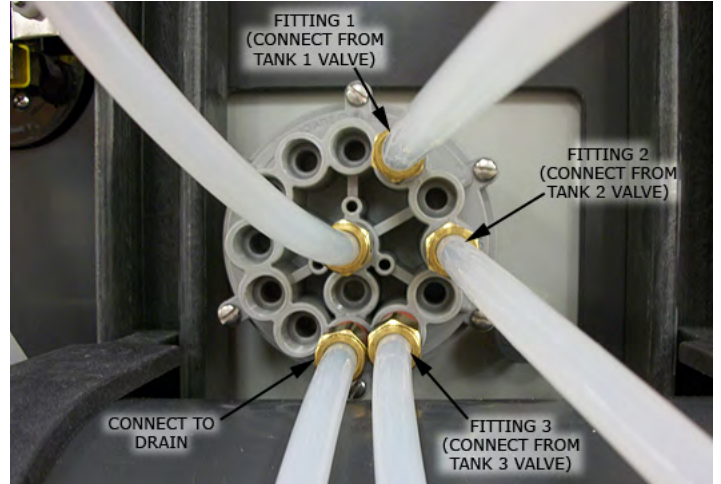

This completes the installation of the backwash controller (CS400) for multiple tank systems. Please see Owner's/Operator's Manual for backwash controller set up and operation.

2.6 Operation (Semi-Automatic Controller)

The diaphragm valve style face piping kits are designed for simple operation and maintenance. Backwashing is accomplished by turning a single knob to actuate the diaphragm valves. The automatic controller can be set up to backwash automatically dependant on certain chosen parameters, as well manually if required (refer to automatic controller manual for more information). The systems backwash one tank at a time, and in the case of the dual tank systems, each tank is backwashed with clean, filtered water.

The following section will explain briefly how to set the multiport pressure, when to backwash the tanks, how the controllers work, how to initiate a backwash cycle, and how to address maintenance issues.

Setting the Multiport Pressure

The multiport pressure is crucial to the operation of both the automatic and semi-automatic controllers. The pressure of the water supplied is what actuates the valves in the system. For the valves to actuate properly there must be 35-40 psi of water pressure supplied to the controller. Both controller kits come with a regulator to adjust the pressure of the supplied water. For the semi-automatic controller kit, the regulator can be located by following the tube from the back of the multiport pressure gauge. For the automatic controller kit, the regulator is located on the top right side of the multiport valve enclosure, next to the multiport pressure gauge. The regulator can be adjusted by turning the top knob (with the slot) with a flathead screw driver. Turning the knob clockwise increases the pressure and counter clockwise decreases pressure. Adjust the regulator until the multiport pressure gauge reads between 35 psi and 40 psi.

When to Backwash

Backwashing is the process which is used to clean the filter tanks. There are many ways to determine when to backwash the filters as explained in the Tank Owner's/Operator's Manual, however, the method that is most commonly used with the semi-automatic and automatic controllers offered is the pressure differential method (see Section 4.1 of the tank manual). Both types of controllers offer gauges to monitor influent and effluent pressures to make determining when to backwash easy.

Semi-Automatic Controller Operation

Controller Overview

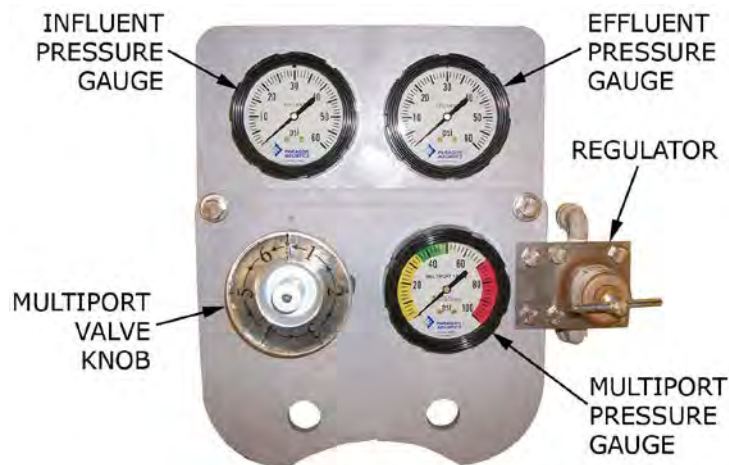

The semi-automatic controller consists of a single gauge panel with gauges to measure influent and effluent pressures, water pressure supplied to the multiport valve, and the multiport valve knob, which is used to actuate the valves.

The influent and effluent pressure gauges show the water pressure coming into and out of the filter system. This information will be useful in determining when the tanks need to be backwashed. The influent pressure should always be higher than the effluent. If it is not, please refer to the troubleshooting section of this manual for assistance.

The multiport pressure gauge shows the water pressure supplied to the multiport valve. **This gauge should read at least 35 psi for proper valve operation.** The water supplied to the multiport valve is what actuates the diaphragm valves. If insufficient water pressure is supplied, the valves may not actuate fully. This can lead to insufficient backwashing of the sand bed, which will diminish the effectiveness of the filters.

The multiport valve knob is what is used to initiate the backwash cycle. On it there will be numbers, which correspond to the tanks, and the word home. When turned to position 1 it will backwash tank one. If there are 2 tanks in the system then position 2 will be used to backwash tank two. The home position is for use in normal filtration mode.

Switching to Backwash Mode

The following are the steps to follow to initiate a backwash cycle with a semi-automatic controller. This can be used for both single and dual tank systems.

NOTE: Before actuating the multiport valve, it is recommended that the filter feed pump be turned off. Make sure all isolation valves to the feed pump are in their open position.

STEP 1: Rotate the multiport valve to position 1. This actuates the diaphragm valves. The pressure reading on the multiport pressure gauge will drop as water is allowed to flow into the tops of the valves via the 3/8" polyethylene tubing.



STEP 2: Verify that multiport pressure gauge returns to normal pressure. When actuating the valves the pressure to the multiport valve drops. When the valves become actuated the pressure gauge will begin to rise, and should return to its preset value (35 psi minimum). At this point, the valves are fully actuated. If the pressure does not return to its initial value, please consult the troubleshooting section of this manual. After the pressure has returned to normal, proceed to step 3.

STEP 3: Backwash the tank for 3-5 minutes. After the valves actuate, the filter is now running in backwash mode. Water should be coming out of the waste pipe and going to the drain. The filter tank should be backwashed 3-5 minutes, or until the water in the sightglass runs clear. When the water runs clear, the tank is cleaned. **If there is more than one tank in the system proceed to step 4. If the system consists of only one tank, proceed to step 6.**

STEP 4: Rotate the multiport valve to position 2. This will actuate the valves to backwash tank 2.



STEP 5: Follow steps 2 and 3 as explained above.

STEP 6: Return the multiport valve to the “Home” position. This will set system back into normal filtration mode.



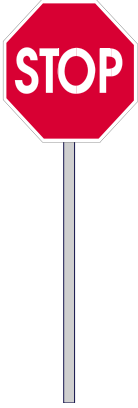

Once system piping and proper valve installation is complete. Including hydraulic lines for valve activation. Hydro test system*. This must be done **prior to adding media**, start pump, allow system to fill with water to (bleed out all air). Run system for several minutes while doing this inspect for leaks and any unnecessary vibrations that can be reduced by additional support. At this time you will be checking that the pump is providing the flow and pressures in the desired system. Once this is done and installer is satisfied the previous criteria has been met, you may proceed in media installation. Failure to do this may result in damaged parts within the system, which may result in the warranty being voided.

2.7 Inspection of Components

Before performing the initial start up of the filter system, inspect the tanks and components to ensure that no damage has occurred during the shipment of the vessel.

- **Check for loose, damaged, and missing laterals.** If they are loose, tighten them to hand tight, making sure that the slots are facing down. Missing or damaged laterals can result in returning the sand media from the filters to the pool, and must be replaced.

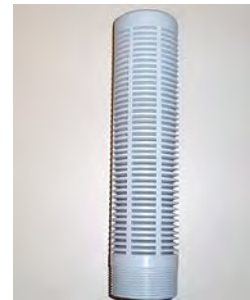

Lateral

- **Check for loose, damaged, and missing diffusers.** These are a key component in flow distribution in the tank. If they are loose, tighten them to hand tight. Missing or damaged diffusers should be replaced.



Diffuser

- **Check effluent piping grooved coupling connection** to make sure it has not become loose during shipping. If the coupling bolts have become loose, tighten them.
- **Make sure automatic air relief is attached properly.** This mechanism assists in bleeding off air, which may become trapped in the top of the tank. Tanks with top Effluent connections it is located on the effluent pipe near the top of the tank, and should be installed with the screen pointing up. Tanks with Effluent connections in dome it is located in Effluent pipe and terminates at top of tank near diffusers.



Automatic Air Relief Assembly

2.8 Pressure Test System

⚠ WARNING: Filters should never be tested or subjected to air or gas under pressure. All gases are compressible, and under pressure create a danger. Severe bodily injury or property damage could occur if the filter is subjected to air or gas pressure.

CAUTION: DO NOT exceed the maximum working pressure of the vessel (Refer to tank label for specific working Pressure) during testing or operation.

NOTE: DO NOT install media prior to pressure testing the system.

- **Install the manway cover** (See section 4.4) and check that all piping connections, manual air relief cap, and media drain cap are tight.
- **Fill the system with water.** Make sure to bleed all air out of the tanks using the manual air relief cap.
- **Pressurize the system.** Caution: DO NOT exceed working pressure.
- **Inspect all installed filtration equipment,** focusing on solvent welded connections, mechanical connections, and all tank penetrations.

NOTE: In the unlikely event that a leak is attributed to the vessel, consult the equipment supplier before proceeding with any tank repairs. Unauthorized repair attempts may void the factory warranty.

- **Drain the tank(s).** It is important to read section (4.3) for proper instructions.
- **Make repairs if necessary.** Before proceeding further, all repairs should be made at this time.

NOTE: Do not perform the following step until the system is pressure tested and all leaks are repaired (See Start-Up and Installation).

2.9 Media Installation

- **Consult Appendix B for media specifications.**
- **Partially fill the tank with water.** This will help prevent damage to the internal piping when installing the gravel.
- **Install the gravel media.** This layer should reach to the top of the effluent laterals and be level.
- **Install the sand media.** This layer should reach to approximately the centerline of the tank. The sand bed should be level and smooth. See pictures at right for example.



Above: Sandbed should be flat and smooth when sand is installed.

3 Start-up and Operation

The following steps should be followed in the order shown for initial start up of the filter system. Each section will be explained in more detail in the following pages.

1. Start system in backwash mode
2. Backwash each tank until clean
3. Start system in normal filtration mode

3.1 Backwash System

After the media is in place, reinstall the manway cover and fill the system with water. It is again important that all air in the tank(s) be bled out using the manual air relief fitting on the top of the tank(s). Once all of the air in the tanks is released, you may begin the initial backwash of the tanks. Each tank should be backwashed for at least 5 minutes to remove any dust or dirt from construction, as well as the “fines” in the media. When the wastewater coming from the backwashed tank runs clear and is free of grit, the tank has been fully backwashed. Repeat this for all tanks in the system. For some instances it may be necessary to repeat this backwash procedure a second time in order to ensure that all “fines” have been removed.

Some things that should be noted during the backwash cycle:

- Adequate backwash flow (Approx. 15-20 GPM per square foot of filtration area)
- Quality of water flowing to waste (i.e. dirt, grit, etc.)

During a backwash the pressure through the system may differ from when it is in filtration mode. This is normal, however it is important to make sure that the pressure does not exceed the operating pressure of the tank.

3.2 Return Filters to Normal Filtration Mode

After backwashing is complete, run the system in normal filtration mode. Once this is done, you should take note of the following:

- **Inspect pool water returns for sand.** If the filter is returning sand to the pool, turn off the system immediately. Refer to the Appendix C for further information.
- **Verify pressure differential through the vessels is within an acceptable range.** Refer to Appendix A for pressure drops through the tanks only. Please be aware that depending on where the pressure readings are taken from and the design of piping system, the pressure drops through the system will be greater than what is shown in Appendix A. Please consult the water circulation system designer for more details.
- **Note the pressure differential over the now clean filter system.** If the system is filtering within an acceptable pressure loss range, with the maximum pressure not to exceed 50 psi, then the filter(s) can be considered clean. Please note the differential pressure, as it may be needed later to determine backwash schedules. See section 4.1 for more details. Appendix D, which will be referred to later, provides a chart to log these pressures into for future reference.

Congratulations, your filter is now ready to filter water. Please read the next section on Maintenance to learn how to care for your new filter tank(s).

4 Maintenance

Although a Stark™ High Rate Sand Filter vessel is designed to operate for many years with little maintenance, there are some items that should be periodically inspected. In certain situations, periodic maintenance may be necessary. The following is a list of items that should be checked periodically, as well as some maintenance items, which may need to be performed.

IMPORTANT: When performing maintenance, which requires entry into the tank, VERIFY that all water sources to the tank are isolated and locked and tagged out before entering tank. This is a confined space situation and all rules and safety guidelines set forth by OSHA regarding such situations should be strictly followed.

4.1 Periodic Backwash

If you have purchased the vessel(s) with the optional face piping kit, please refer to documentation provided with the face piping kit.

The tanks need to be backwashed when the sand bed becomes clogged with debris from the pool. There are a few different ways to determine when backwashing should occur. The following are the most common methods, however depending on piping design; backwash frequency can be determined in a different manor if desired.

- **Pressure Differential.** When tanks become dirty, the pressure through them increases. During the initial pressure test of your tank(s), the pressure through the clean filter(s) should have been noted and recorded. This is your clean filter pressure differential. When the filter pressure increases by 10 psi above this clean filter pressure, the tank(s) should be backwashed.
- **Time Schedule.** If desired, the system can be backwashed based on a time schedule, such as once a week. This is up to the user as to when to backwash the tank(s), however it is recommended that backwashing occur often enough so the tanks don't become too clogged. This may be especially necessary after periods of increased bather load.

When backwashing, it is important that there is:

- **Sufficient Backwash Time.** It is recommended to backwash each tank for at least 5 minutes
- **Sufficient Backwash Flow Rate.** The flow going through the tank in backwash mode must be in the range of 15 to 20 GPM/ft² in order to accomplish an adequate backwash.

NOTE: It may be necessary in some instances to backwash the tanks more than once to achieve a clean sand bed.

It is recommended that the influent and effluent pressures be recorded at the time of each backwash. Appendix D has been provided to record these pressures. This information may be useful in determining backwash frequency. It may also be useful in troubleshooting some types of problems.

4.2 Periodic Inspection of filters

Part of the maintenance schedule that is suggested for these tanks is to check certain areas of the filter tanks for signs of possible problems. Below are some key areas, which should be inspected regularly.

- **Inspect Media Bed.** The sand media bed should be inspected on a yearly basis, or whenever the system is drained for maintenance. The sand bed should be smooth and level. A difference in sand elevation between the highest and lowest points of the bed that is 3" or more may indicate a problem which may require further investigation. This may indicate that there may be damaged internal tank components such as diffusers or laterals.



Above: Typical sand beds after draining tanks. Note the smooth, flat sand bed. There are no signs of trenching or erosion.

Below: The sand beds shown below may indicate a problem. Note the trenches and erosion of the media, which has developed.



- **Inspect tanks for leaks.** The system should be inspected periodically for leaking around the influent/effluent piping penetrations, drain port, manual air relief fitting, and on the outside shell of the tanks. A quick visual sight inspection is all that is needed to accomplish this. **In the unlikely event that a leak is attributed to the vessel, consult the equipment supplier before proceeding with any tank repairs. Unauthorized repair attempts may void the factory warranty.**
- **Take note of system parameters (Influent/Effluent pressure).** This is especially important if you are not using an automatic backwash control system. These parameters are prime indicators as to whether or not a backwash cycle needs to be run. They should be checked every couple of days, particularly after periods of increased bather load.

4.3 Draining the Filters

Some maintenance may require the Stark™ High Rate Sand Filters to be drained of all water. To accomplish this you must:

- **Make sure that the system is shut down.** Isolate all water sources from the filter(s).
- **Remove the drain cap located on the bottom of the front of the tank (SS/RS) or on the side of the tank (4X & 5X).** See figure below for location.
- **Disconnect the effluent piping flanged connection (SA/B/C style ONLY)**
- **Open the manual air relief on top of the tank.** This will allow the water to drain faster as well as to prevent the creation of a vacuum in the tank.

NOTE: A vacuum condition in the tanks can damage the tanks and possibly other components in the filter system.

- **Replace Caps or tighten flange bolts after water is drained**

4.4 Installation/Removal of Manway Cover

NOTE: It is important that the manway yokes never be removed during operation of the tanks. The tanks should be drained before removing manway cover.

Removal:

- **Drain the tanks.** See section 4.3 for instructions.
- **Remove one yoke bolt and yoke.** This will require a 1 1/8" wrench. Loosen the second bolt, but do not remove the second yoke.
- **Remove cover from tank.** Rotate remaining yoke 90° and push cover into tank. Turn the cover so that it will pass through the manway opening and remove the cover. Make sure the manway gasket is with the cover. If not, look for it on the manway opening or inside the tank.

*Manway cover may differ from picture below



Gasket ring

Installation:

- **Ensure there are no tools, construction materials, or foreign objects in the tank.**
- **Clean the sealing surfaces of the cover and manway opening.** Make sure they are free of dirt and debris.
- **Install gasket ring on manway cover.** See picture at right for correct location.
- **Maneuver the cover back into the tank so it fits back in the manway opening.** Follow removal directions in reverse order.



Correct yoke orientation

- **Install yokes, bolts, and washers.** Make sure the yokes are in the proper locations. See picture at right.
- **Snug yoke bolts.** Tighten bolts one full turn past hand tight. If manway leaks during refilling of system, tighten bolts in quarter turn increments until leak stops. After filter is at operating pressure, yokes will be loose due to internal pressure. Snug bolts until yokes no longer move. DO NOT exceed 15 ft/lbs of torque.

4.5 Removal of Sand Media

The sand media in the filter should be removed when:

- **Media bed has become contaminated.** The media bed can become contaminated due to the introduction of an unwanted substance into the water, such as fecal matter, chemicals, etc. While the filters will take out the particulate matter of the contaminate and prevent it from returning to the body of water, the contaminate will become embedded in the media. This can affect pool chemistry.
- **Filters need to be moved from their current location.** While these tanks are designed to withstand internal pressure, they are not designed to be transported with the added weight of the media inside of them. It is therefore necessary to remove as much media as possible before relocating the filters.
- **Inspections/repairs need to be made to inside of tank or internal components.** In order to reach certain components or areas of the tank, the sand has to be partially or removed. These areas include laterals, effluent piping, media drain assembly, inside walls of the filter.

If you need to remove the media the tanks must be drained first, see Draining Filters section. After draining the filters, remove the manway cover (see Section 4.4). Removal can be done by a variety of means, from using an ordinary shovel, to adding water to the sand and removing the slurry with a pump truck. **It is important that if using shovels or other devices with edges, corners, etc. that care be taken to not scratch the inside walls of the tank.** The inside walls are coated with a material that protects the water from exposure to the fiberglass walls of the tanks.

Remove only as much material as required to perform any maintenance operations. If all of the sand needs to be removed for the purpose of replacement due to contamination, be sure to rinse out the tank with clean water. It may be necessary to backwash the tank(s) after rinsing to remove sand stuck in the laterals. Follow the backwash procedures outlined earlier in this section.

4.6 Winterizing the filter tanks

In areas where the tanks will not be in service during the winter months, or where tanks may see freezing or below freezing temperatures, it is recommended that the tank(s) be winterized. This will protect the tank(s) from being damaged due to ice expansion. Some items that may be damaged due to this may include internal piping, internal components, and tank walls. Below are the steps that should be performed when winterizing the tank(s):

- Thoroughly backwash each filter to remove foreign contaminants from the filter bed prior to draining the system
- Shut off all electrical power to the filter system.
- For SS/RS, 4X and 5X style tanks drain by removing the drain plug from the tank (See Section 4.3). For A/B/C style tanks remove the bolts from the effluent piping flanged connection and separate the fitting. Opening the manual air relief valve cap will help in allowing the water to drain out of the filters, as well as preventing a vacuum condition from occurring.

- When the water is drained from the system, drain all of the water in the backwash line.
- Loosen any flanges in low-lying sections of piping to completely drain the system of water.
- Store any plugs/caps removed near the filter and mark all flanges that have been loosened so that they may be reinstalled and tightened at time of start up.

APPENDIX

| | |
|------------|---|
| APPENDIX A | PRESSURE DIFFERENTIAL CURVES |
| APPENDIX B | MEDIA REQUIREMENTS |
| APPENDIX C | TROUBLE SHOOTING |
| APPENDIX D | BACKWASH LOG |
| APPENDIX E | TANK SPECIFICATIONS R-Series (36" Diameter, Wound) L-Series (42" Diameter, Unwound) S-Series (42" Diameter, Wound) 4X-Series (48" Diameter) 5X-Series (60" Diameter) 5S-Series (60" Diameter) |
| APPENDIX F | TANK PART DRAWINGS R-Series (36" Diameter, Wound) L-Series (42" Diameter, Unwound) S-Series (42" Diameter, Wound) 4X-Series (48" Diameter) 5X-Series (60" Diameter) 5S-Series (60" Diameter) |
| APPENDIX G | Replacement Parts |
| APPENDIX H | Hydraulic Valve Piping Schematics |

APPENDIX A

R Model Filter Pressure Drop Curves

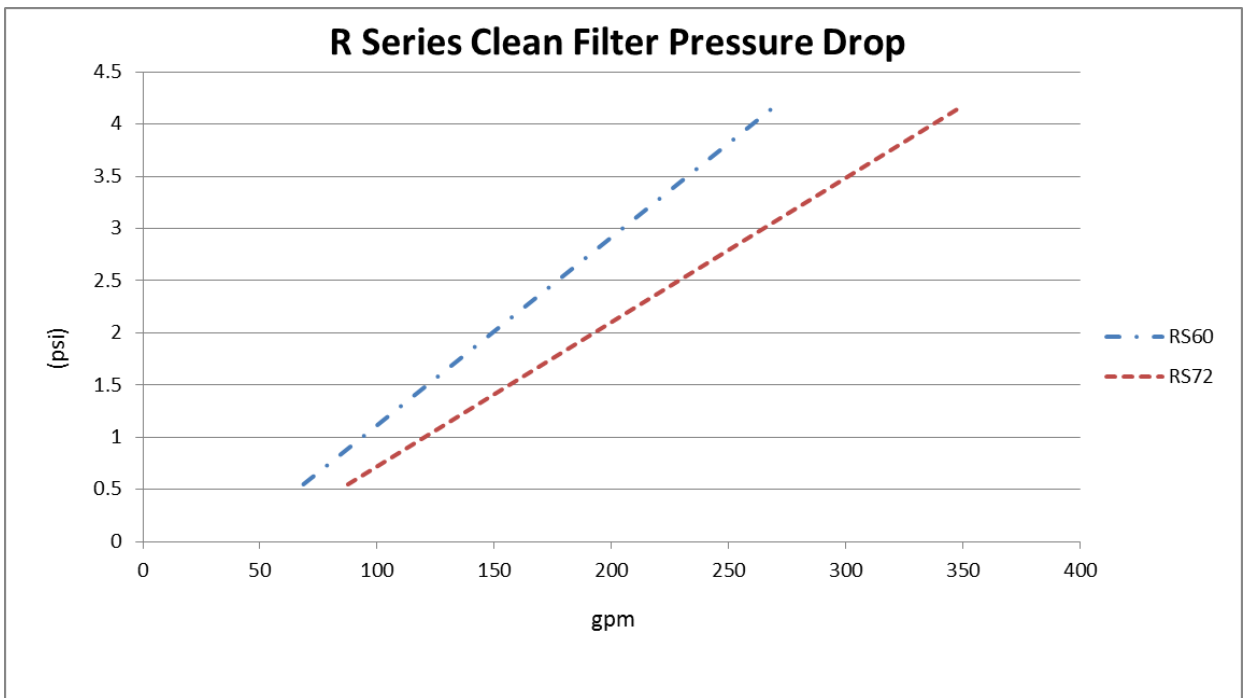
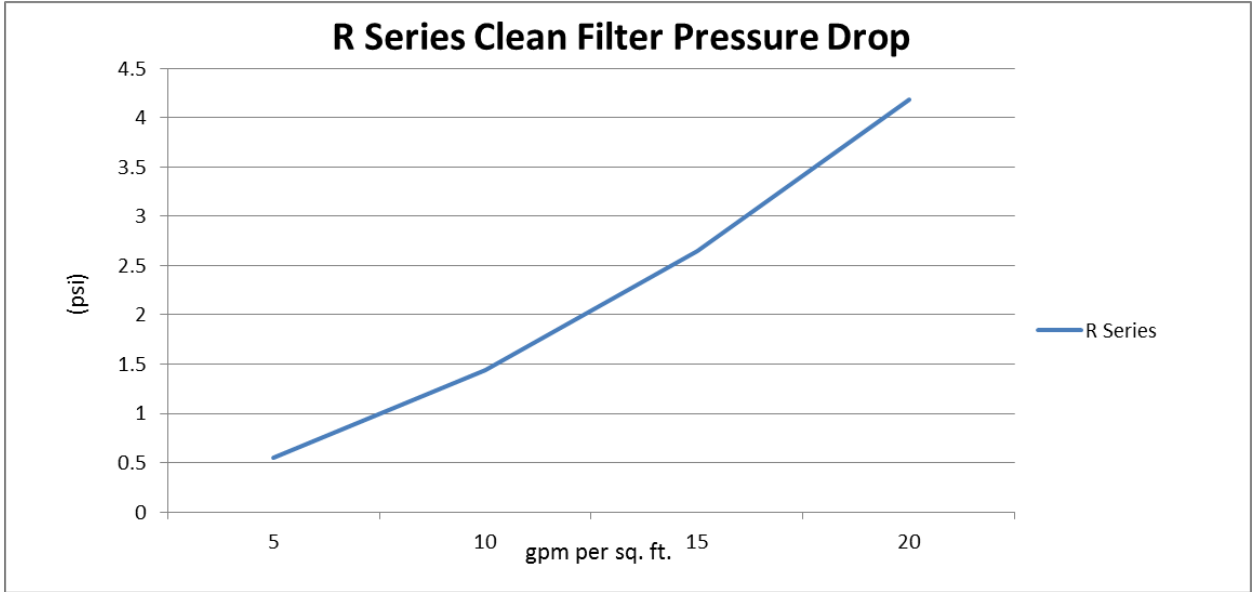

S Model Filter Pressure Drop Curves

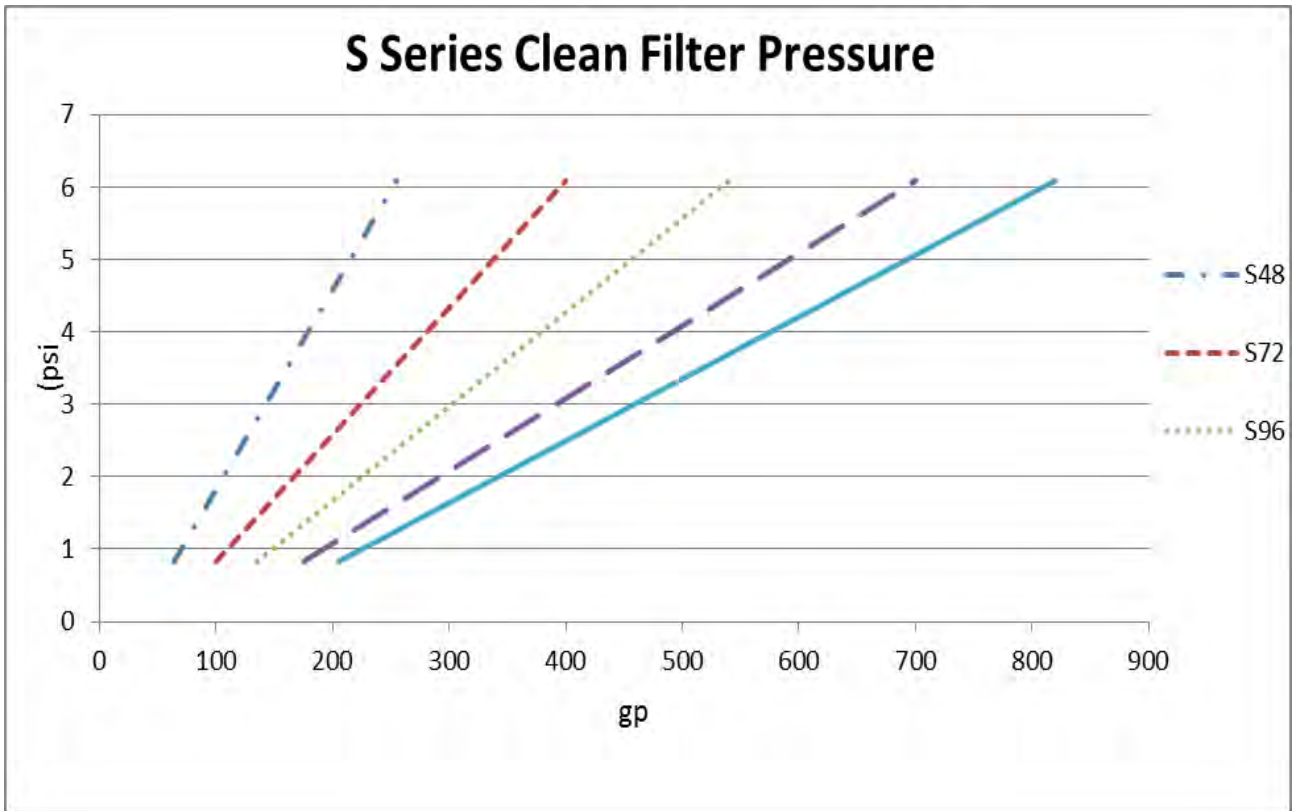
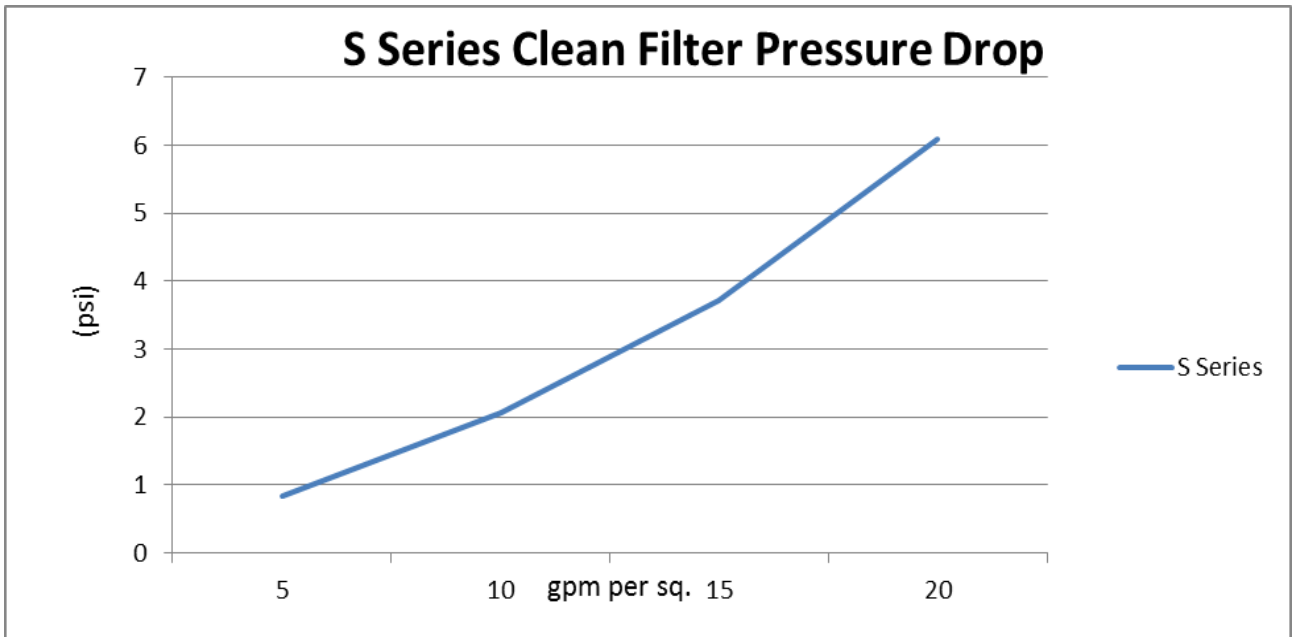

4X Model Filter Pressure Drop Curves

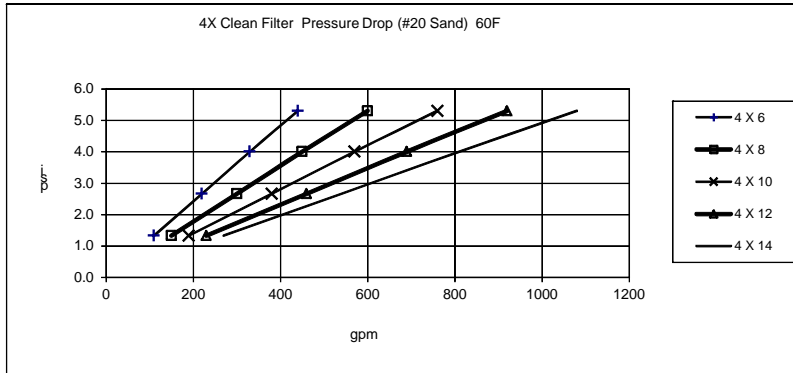
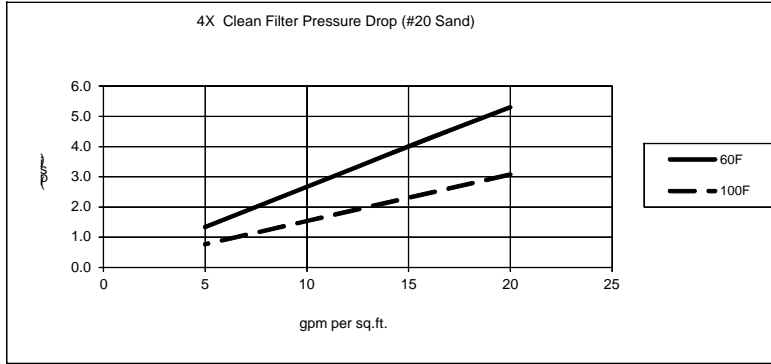

5x Model Filter Pressure Drop Curves

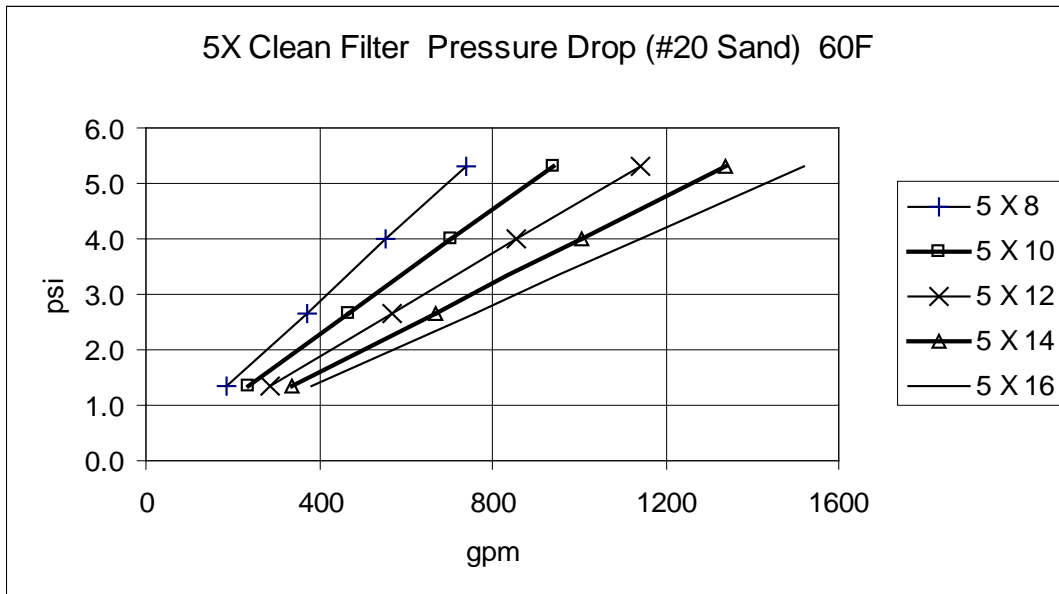
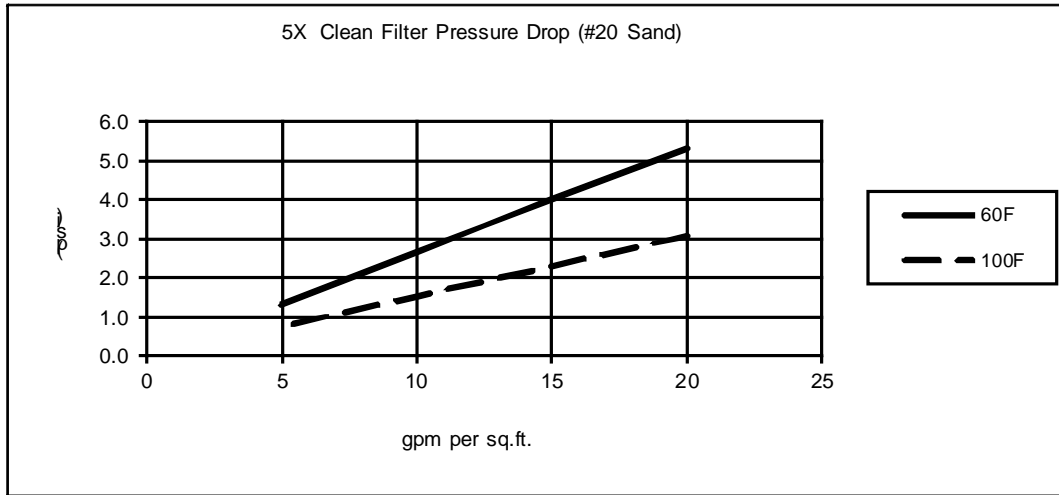

5S Model Filter Pressure Drop Curves (Sand)

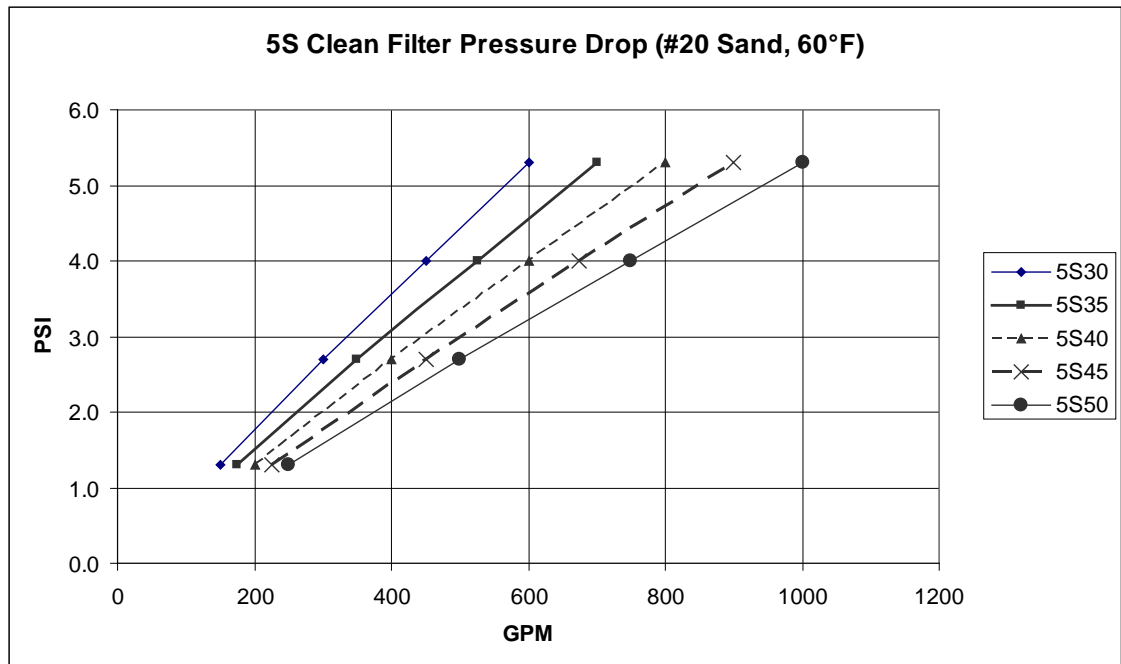
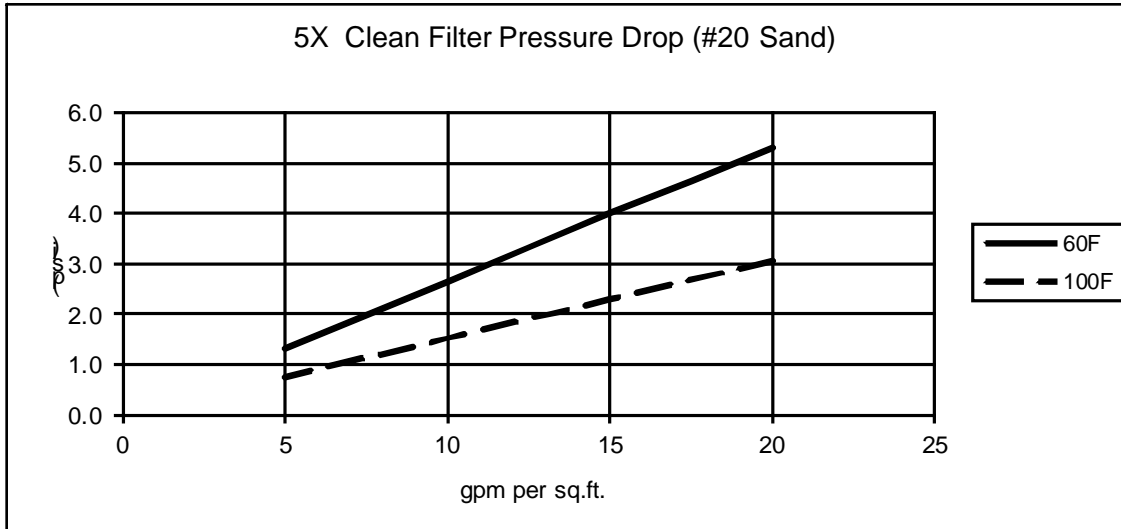

APPENDIX B (For Sand and Gravel)

| Media Requirements: Sand (**and Gravel) | | | | | | | |
|---|--------------------------------|-----------------------------------|----------------------------------|------------------------------------|-----------------------|----------------------|-------------------|
| Filter Model | Filter Area (Ft ²) | Media Required (Ft ³) | Sand Required (Ft ³) | Gravel Required (Ft ³) | Freeboard Height (in) | Media Bed Depth (in) | Gravel Depth (in) |
| R-60 | 13.5 | 15.5 | 12.5 | 3.0 | 10.0 | 12.5 | 6.0 |
| R-72 | 17.2 | 19.0 | 15.5 | 3.5 | 10.0 | 12.5 | 6.0 |
| S-48 | 12.8 | 14.5 | 12.0 | 2.5 | 12.5 | 16.0 | 6.0 |
| S-72 | 20.0 | 26.0 | 22.0 | 4.0 | 12.5 | 16.0 | 6.0 |
| S-96 | 27.0 | 36.0 | 31.0 | 5.0 | 12.5 | 16.0 | 6.0 |
| S-120 | 35.0 | 45.5 | 39.0 | 6.5 | 12.5 | 16.0 | 6.0 |
| S-144 | 41.0 | 55.5 | 47.5 | 8.0 | 12.5 | 16.0 | 6.0 |
| 4X6 | 22.0 | 36.0 | 29.0 | 7.0 | 16.2 | 18.0 | 7.5 |
| 4X8 | 30.0 | 49.0 | 40.0 | 9.0 | 16.2 | 18.0 | 7.5 |
| 4X10 | 38.0 | 63.0 | 51.0 | 12.0 | 16.2 | 18.0 | 7.5 |
| 4X12 | 46.0 | 80.0 | 63.0 | 17.0 | 15.7 | 18.0 | 8.0 |
| 4X14 | 54.0 | 93.0 | 74.0 | 19.0 | 15.7 | 18.0 | 8.0 |
| 5S30 | 30.0 | 63.5 | 39.0 | 24.5 | 17.8 | 18.0 | 15.0 |
| 5S35 | 35.0 | 74.3 | 46.6 | 27.7 | 17.8 | 18.0 | 15.0 |
| 5X8 | 37.0 | 79.0 | 53.0 | 26.0 | 17.8 | 18.0 | 15.0 |
| 5S40 | 40.0 | 85.4 | 53.8 | 31.6 | 17.8 | 18.0 | 15.0 |
| 5S45 | 45.0 | 96.4 | 61.0 | 35.4 | 17.8 | 18.0 | 15.0 |
| 5X10 | 47.0 | 101.0 | 68.0 | 33.0 | 17.8 | 18.0 | 15.0 |
| 5S50 | 50.0 | 107.4 | 68.2 | 39.2 | 17.8 | 18.0 | 15.0 |
| 5X12 | 57.0 | 123.0 | 83.0 | 40.0 | 17.8 | 18.0 | 15.0 |
| 5X14 | 67.0 | 145.0 | 99.0 | 46.0 | 17.8 | 18.0 | 15.0 |
| 5X16 | 76.0 | 167.0 | 114.0 | 53.0 | 17.8 | 18.0 | 15.0 |
| 8X16* | 124.0 | 378.0 | 258.0 | 120.0 | 34.0 | 27.0 | 22.0 |

*-Filter model not NSF Listed.

**-Sand may be used instead of gravel.

Sand Specification:

Sand to be #20 Standard Sand Silica.
 Effective Size: 0.45-0.55mm (.018"- .022")
 Uniformity Coefficient: Less than 1.5
 Specific Gravity: 2.65

Gravel Specification:

Pea Gravel to be 1/8" to 1/4" diameter rounded particles.
 Specific Gravity: Not less than 2.5

Note: The Gravel and Sand should be washed, screened and contain less than one percent of loam, clay, shells, dirt, inorganic impurities and other foreign matter.

APPENDIX C

| Problem | Possible Cause | Solution |
|---|--|--|
| Source water not sufficiently clear | 1. Water chemistry not in balance | Maintain pool chemistry. Consult pool service technician |
| | 2. Incorrect media installed | Verify media size with media vendor. Consult Appendix B of this manual for proper media sizing. If the media is the incorrect size, replace with proper media. |
| | 3. Filter system not being backwashed properly | The tank(s) may not have been backwashed enough upon initial start-up. Repeat the backwash procedure for initial start-up (see Start-up and Operation section). Backwash each tank twice to ensure that the media bed is clean and free of debris. |
| | 4. Rate of flow in excess of 20 GPM/ft ² of filter area | Adjust the flowrate through the filters. These filters are designed to operate at a maximum of 20 GPM/ft ² . If flow rates are in excess of this, the media bed will not perform as designed. |
| | 5. Inadequate turnover rate | The turnover rate is the amount of time it takes the filters to pass the entire volume of the pool through the filter system. Filtration systems for pools are typically designed to operate at a turnover rate of 1-6 hours typically depending on the application and appropriate codes. If the filter system is filtering the water too slow, dirt and debris can build up faster than the water is cleaned. The flow through the filters may need to be increased. Consult the manufacturer before changing the filtration parameters. |
| Filtration media being discharged into the filtered body of water | 1. Incorrect media installed | Verify media size with media vendor. Consult Appendix B of this manual for proper media sizing. If the media is the incorrect size, replace with proper media. |
| | 2. Damaged effluent piping/lateral | The tank(s) must be drained of water (see Maintenance section) and all media removed. Once this is done, an inspection of all internal piping should be performed. If any laterals are broken, cracked, or missing, they should be replaced. If the main effluent pipe in the tank is cracked, consult the manufacturer for repairs. |
| High filtration pressure differential | 1. Filter system not being backwashed properly | The tank(s) may not have been backwashed enough upon initial start-up, backwashes may be too infrequent, or there may not be enough backwash flow. Check the backwash flow rate on the waste pipe to verify that enough backwash flow is present. A minimum of 15 GPM/ft ² of filtration area is recommended. |
| | 2. Impacted sand bed | Sometimes the sand media may become compressed, which inhibits the flow of water through it. If an impacted sand bed is suspected, the tanks should be drained and the media should be loosened by turning over the top 6"-10" of sand. After this, a backwash cycle should be run before returning the filter to filtration mode. |
| Excessive sand media being lost to waste drain | 1. Backwash flow rate is too high | If the flow rate is too great, it will force some of the sand media out through the diverters and into the waste drain. Reduce the flowrate slightly to the filters when performing a backwash. |
| | 2. Incorrect media installed | Verify media size with media vendor. Consult Appendix B of this manual for proper media sizing. If the media is the incorrect size, replace with proper media. |
| Leak at manual air relief, manway, or tank drain port | 1. Improperly tightened assembly | With the pump off, isolate the tanks from the system and relieve the tank of any pressure using the manual air relief valve. If leak has occurred in an area which is below the water level in the tank, drain the tank until water line is below the leak (see Maintenance section). Remove the assembly and inspect the sealing surfaces for dirt and debris. Clean all sealing surfaces. If the assembly is still in usable condition, replace the assembly and pressure test the system (see Start-up and Operation section). If the assembly appears broken or defective, replace with a new factory part (see Appendix X for part number). After replacement pressure test the system before restoring it to normal filtration mode. |
| | 2. Dirt or contamination on sealing surface | |
| | 3. Damaged part | |

APPENDIX D

| Date | Time | Pressures for Dirty Filter (Psi) | | ΔP Dirty Filter =(Influent - Effluent) (Psi) | Pressures for Backwashed Filter (Psi) | | ΔP Clean Filter =(Influent - Effluent) (Psi) |
|----------|----------|----------------------------------|----------|--|---------------------------------------|----------|--|
| | | Influent | Effluent | | Influent | Effluent | |
| Start-up | Start-up | n/a | n/a | n/a | | | |
| | | | | | | | |
| | | | | | | | |
| | | | | | | | |
| | | | | | | | |
| | | | | | | | |
| | | | | | | | |
| | | | | | | | |
| | | | | | | | |
| | | | | | | | |
| | | | | | | | |
| | | | | | | | |
| | | | | | | | |
| | | | | | | | |
| | | | | | | | |
| | | | | | | | |
| | | | | | | | |
| | | | | | | | |
| | | | | | | | |
| | | | | | | | |
| | | | | | | | |
| | | | | | | | |
| | | | | | | | |
| | | | | | | | |

1. After performing the backwash for the initial start up, and returning the filter to normal operation, record the clean filter influent and effluent pressures into the first line of the chart and calculate ΔP for a clean filter. It is recommended that backwashing occur when the pressure differential increases by 10 Psi from this value.
2. Before performing a backwash, log the influent and effluent pressures of the filter system and calculate ΔP for the dirty system. Backwash the system and return to normal filtration mode. Record the influent and effluent pressures for the now clean filter system and calculate ΔP for the clean system.

APPENDIX E

APPENDIX F

APPENDIX G

APPENDIX H



1620 HAWKINS AVE., SANFORD, NC 27330 • (919) 566-8000
10951 WEST LOS ANGELES AVE., MOORPARK, CA 93021 • (805) 553-5000

WWW.PENTAIRCOMMERCIAL.COM

All Pentair trademarks and logos are owned by Pentair or by one of its global affiliates. Pentair Commercial Aquatics™ and Stark™ are trademarks of Pentair Water Pool and Spa, Inc. and/or its affiliated companies in the United States and/ or other countries. Unless expressly noted, names and brands of third parties that may be used in this document are not used to indicate an affiliation or endorsement between the owners of these names and brands and Pentair Water Pool and Spa, Inc. Those names and brands may be the trademarks or registered trademarks of those third parties. Because we are continuously improving our products and services, Pentair reserves the right to change specifications without prior notice. Pentair is an equal opportunity employer.

© 2014 Pentair Water Pool and Spa, Inc. All rights reserved. This document is subject to change without notice.



P/N 155695 REV F 6/9/14