

FEATURE COMPARISON



Previous AT-90

VS.

NEW AT-90+



Yes	Unique to Pentair	Yes	✓
300 lbs	Weight Capacity	400 lbs	✓
Yes	QuickSet Anchor	Yes	✓
Yes	6" Stanchion Anchor	Yes	✓
20"	Max Anchor Setback	36"	✓
11"	Deck to Water	14"	✓
No	Solar Capable	Yes	✓
Yes	Fit existing anchors	Yes	✓



+ Color options

Replace
w/New Version



NEW AquaTRAM 90+ Lift

- **400** lb weight capacity
- Up to **36"** anchor set back distance
- Up to **14"** deck to water distance
- 90 Degree rotation
- Quickset Dual Wedge Anchor System **OR**
- Fits new or existing 6" stanchion anchors
- **Solar Capable**

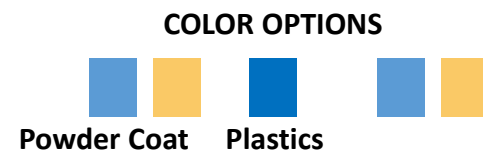

Pentair P/N	Description
11420	AquaTRAM 90+, Square Post, w/Anchor (400 lb cap)
11420-A	AquaTRAM 90+, Square Post, No-Anchor (400 lb Cap)
11421	AquaTRAM 90+, Round Post, w/Anchor (400 lb Cap)
11421-A	AquaTRAM 90+, Round Post, No-Anchor (400 lb Cap)

NEW Dimensions

- In order to accomplish the greater reach, the height is increased by 13", from 4'3" to 5'4"

Previous AT-90

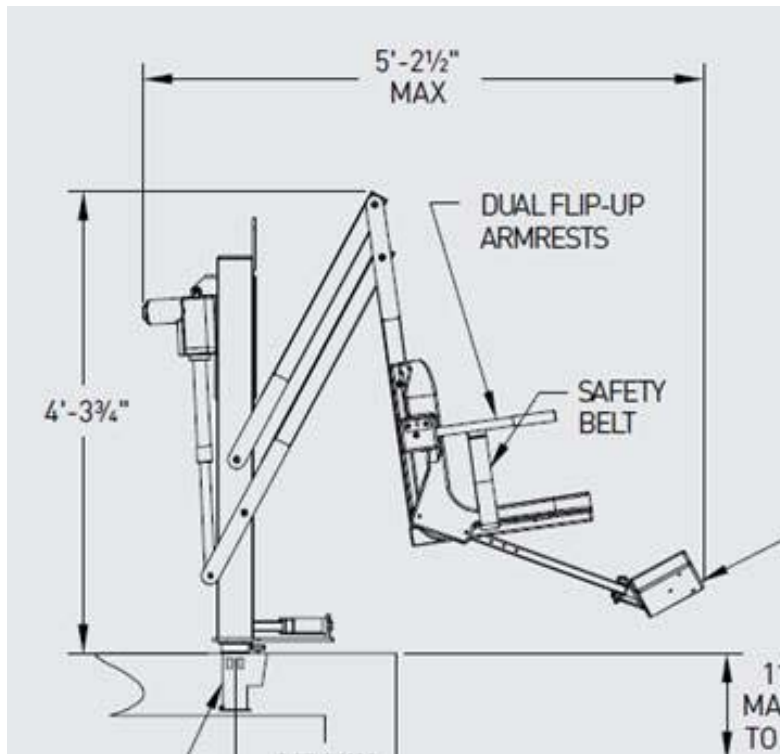

NEW AT-90+

