

# **AQUATRAM™ POOL LIFT USER MANUAL**



## **WARNING**

### **IMPORTANT SAFETY INSTRUCTIONS**

- 1. WARNING- TO REDUCE RISK OF INJURY, DO NOT PERMIT CHILDREN TO PLAY ON THIS PRODUCT.**
- 2. WARNING- DO NOT PERMIT CHILDREN TO OPERATE OR USE THIS PRODUCT.**
- 3. SAVE A COPY OF THESE INSTRUCTIONS.**

© 2011 Pentair Water Pool and Spa, Inc. All rights reserved  
1620 Hawkins Ave., Sanford, NC 27330 • (919) 566-8000  
10951 West Los Angeles Ave., Moorpark, CA 93021 • (805) 553-5000  
AquaTRAM™ and Pentair Water Commercial Pool and Spa are trademarks and/or registered trademarks of Pentair Water Pool and Spa, Inc. and/or its affiliated companies in the United States and/or other countries. Unless noted, names and brands of others that may be used in this document are not used to indicate an affiliation or endorsement between the proprietors of these names and brands and Pentair Water Pool and Spa, Inc. Those names and brands may be the trademarks or registered trademarks of those parties or others.  
P/N 11229 Rev A - 04/18/11

# **AQUATRAM™ POOL LIFT**

**400 LB. [181 kg] MAXIMUM CAPACITY  
MANDATORY – LEAVE THIS MANUAL WITH LIFT OWNER**

## **- READ CAREFULLY-**

Check entire box and inside all packing materials for parts. Before beginning assembly, read the instructions and identify parts using the figures and parts listed in this document. It is critical that all parts be carefully inspected by the installer prior to installation to ensure that no damage occurred in transit and that a damaged part is not used. If any damage occurred in transit, Pentair Water Commercial Pool and Aquatics (“Pentair”) must be notified within three days of receipt of unit. Proper installation cannot be overstressed, as an improper installation will void the warranty, and may affect the safety of the user.



## **WARNING**

### **IMPORTANT SAFETY INSTRUCTIONS**

1. READ AND FOLLOW ALL INSTRUCTIONS. LIFT SAFETY CAN ONLY BE ENSURED IF THE LIFT IS INSTALLED AND OPERATED PROPERLY – AS PER THESE INSTRUCTIONS.
2. WARNING- TO REDUCE RISK OF INJURY, DO NOT PERMIT CHILDREN TO USE OR OPERATE THIS PRODUCT.
3. WARNING- DO NOT PERMIT CHILDREN TO PLAY ON THIS PRODUCT.
4. WARNING- NEVER APPLY DIRECT WATER PRESSURE TO ELECTRONIC COMPONENTS.
5. DO NOT USE THE AQUATRAM LIFT FOR WATER-DRAFTS OVER 9” (DECK TO WATERLINE).
6. NEVER OPERATE THIS LIFT UNDER LOAD WITH NO WATER (DRY POOL).
7. SAVE A COPY OF THESE INSTRUCTIONS.

## **WARNING**

**MAKE SURE THE AREA AROUND THE LIFT IS CLEAR BEFORE OPERATING. NEVER OPERATE THE LIFT WITH ANY PERSON WITHIN THE OPERATING RANGE OF THE LIFT, INCLUDING ON THE DECK OR IN THE WATER. NEVER MOVE THE LIFT DOWN WHILE OVER THE DECK. IF THE LIFT COMES INTO CONTACT WITH THE DECK OR A WALL, RELEASE THE BUTTON IMMEDIATELY OR PRESS THE EMERGENCY STOP BUTTON. DO NOT ALLOW CHILDREN TO OPERATE THE LIFT WITHOUT SUPERVISION.**

**CHECK ALL NUTS AND BOLTS FOR TIGHTNESS AND FOR WORN PARTS BEFORE EACH USE.**

### **AquaTRAM™ Technical Support**

Contact Technical Support at:

**Sanford, North Carolina (8 A.M. to 5 P.M.)**

Phone: (800) 831-7133

Fax: (919) 566-8920

**Web sites:** visit [www.pentaircommercial.com](http://www.pentaircommercial.com)

# **AquaTRAM™ Lift**

## **TABLE OF CONTENTS**

<b><u>PAGE</u></b>	<b><u>DESCRIPTION</u></b>
4	PACKING LIST
5	ADA INSTALLATION GUIDELINES
6	ANCHOR INSTALLATION - RETROFIT
7	ANCHOR INST. – NEW CONSTRUCTION
8	AQUATRAM™ LIFT ASSEMBLY INSTRUCTIONS
9	24V BATTERY OP & INSTALL INSTRUCTIONS
10	BATTERY MAINTENANCE
11	AQUATRAM™ LIFT OPERATING INSTRUCTIONS
12	AQUATRAM™ LIFT HEADREST (OPTIONAL)
13	CARE FOR YOUR LIFT
13-15	TROUBLESHOOTING GUIDE
16	AQUATRAM™ Lift PARTS LIST
17	SEAT ASSEMBLY PARTS LIST
18	OPTIONS
19	WARRANTY

# The AquaTRAM™ Lift

The AquaTRAM Lift will come partially assembled. The figure below shows the main components and points out a few features/details you should be aware of before going any further. The "POST" will be installed into the QUICKSET® DUAL-WEDGE ANCHOR, which needs to be properly installed in a concrete deck (see ANCHOR INSTALLATION). The HANDSET CONTROL will be plugged into the CONTROL BOX (ASSEMBLY INSTRUCTIONS), and can be stored on the HANDSET BRACKET when not being used. The BATTERY CHARGER comes with a WALL BRACKET for easy installation and use. Familiarize yourself with all of the parts and features of the AquaTRAM lift before beginning installation and assembly.

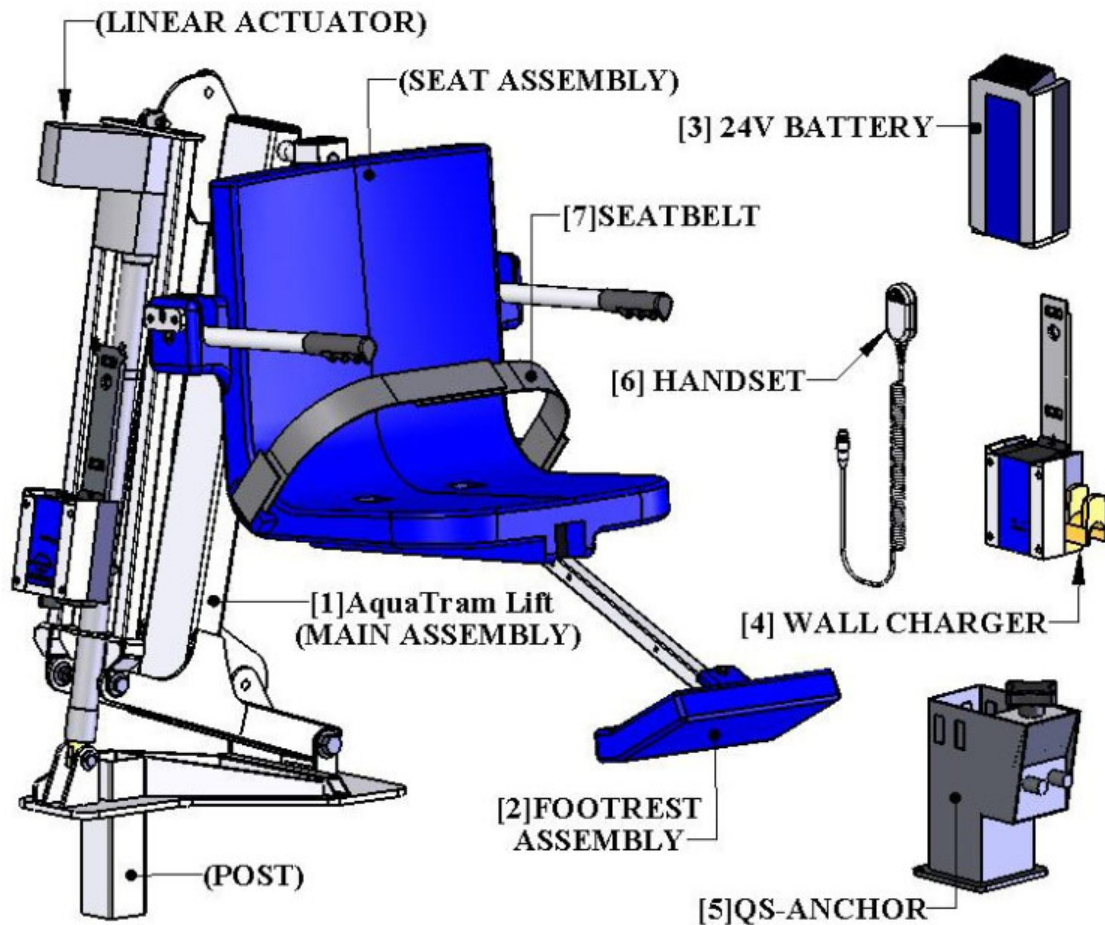

1. AQUATRAM LIFT (MAIN ASSEMBLY)
2. FOOTREST ASSEMBLY (P/N 11213)
3. 24V BATTERY (P/N 11211)
4. WALL (BATTERY) CHARGER (P/N 11277)
5. QUICK-SET-ANCHOR (QUICKSET® DUAL-WEDGE ANCHOR) (P/N 11202)
6. HANDSET (P/N 11270)
7. SEATBELT (P/N 11215)

## INSTALLATION: ADA GUIDELINES

### ADA REQUIREMENTS:

The AquaTRAM™ Lift is designed and manufactured to be 100% ADA compliant. But for the installed lift to be 100% compliant the installation must meet the requirement for CLEAR DECK SPACE as shown in the diagram to the left. To be compliant, install the QUICKSET® DUAL-WEDGE ANCHOR at 23 inches [584mm] (the maximum setback) from the pool edge, and make sure the deck has the required CLEAR DECK SPACE as shown.

**NOTE:** ADA requires a deck slope of no greater than 1:48 as shown.

**NOTE:** The ADA requires the seat to go at least 18" into the water. To make sure the lift has enough clearance the lift should be installed at a location with 42"-48" of depth (deck to pool floor).

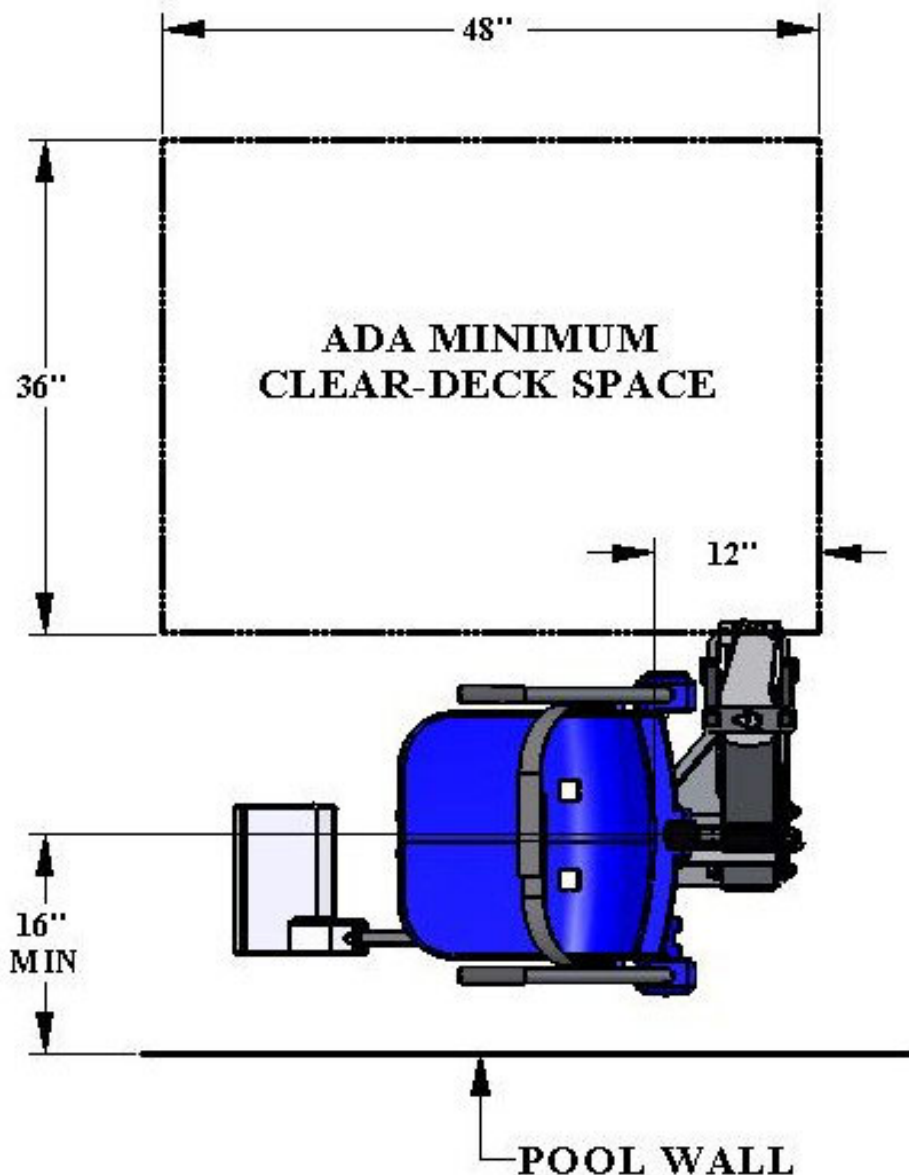

## AQUATRAM™: QUICK-SET® ANCHOR INSTALLATION

NOTE: THE AQUATRAM™ QUICKSET® DUAL-WEDGE ANCHOR CAN BE INSTALLED IN EITHER A NEW POOL DECK OR AN EXISTING DECK. BEFORE INSTALLING MAKE SURE THE WATER-DRAFT IS 9" OR LESS (DECK TO WATERLINE). INSTALL THE LIFT AT A LOCATION WITH 42" TO 48" OF DEPTH.

### RETRO-FIT INSTALLATION / EXISTING DECK:

NOTE: Ensure existing pool deck has been constructed using minimum 3000psi concrete and has been constructed to meet or exceed all applicable local and national building codes.

### REQUIRED TOOLS & EQUIPMENT

- Concrete saw with Diamond blade (or)
- Core-drill setup w/10" core-drill bit
- Tape Measure
- 4' long Straight edge or chalk line
- Sledge Hammer
- Cold Chisel
- Torpedo Level
- String line
- Concrete & Concrete tools

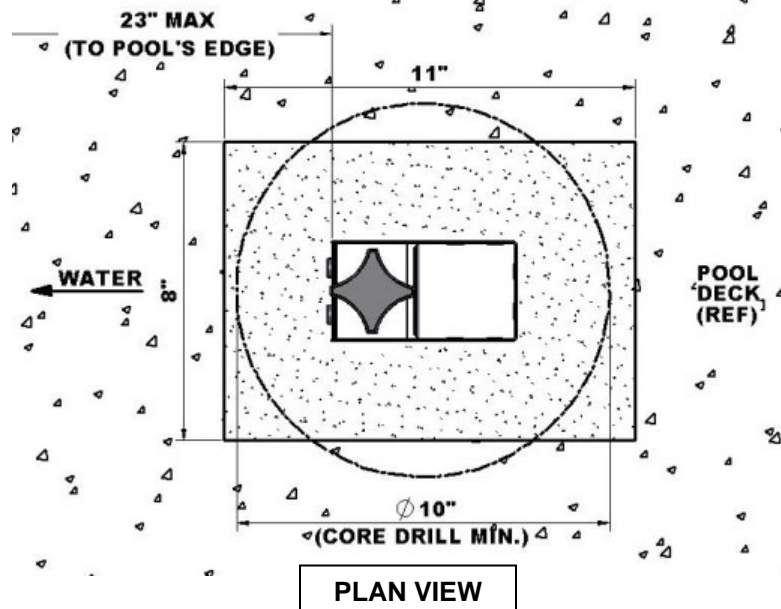
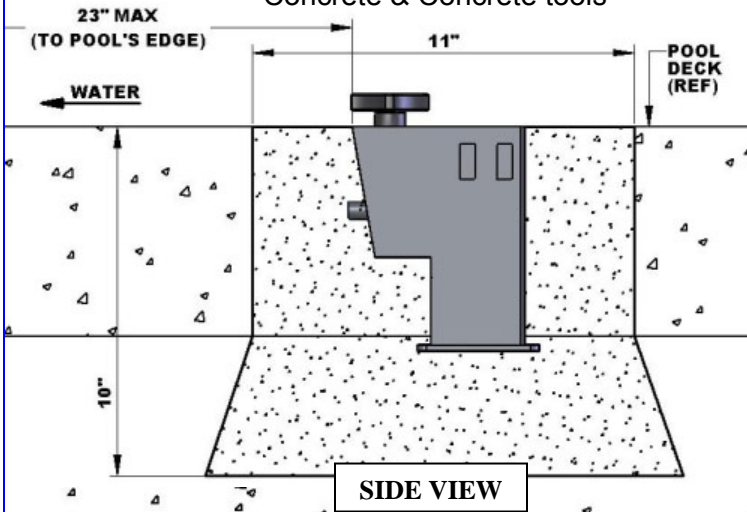

1. Mark out a section of the pool deck that you are removing using a chalk line or straight edge and a marker. You will be saw-cutting an 11" x 8" section, or core-drilling a 10" diameter hole. The finished hole should be 10" deep, with the front edge of the anchor no more than 23" from the pools edge.
2. Using the saw with the diamond blade, make your cuts along the lines that you marked. Or, using the core-drill rig, wet-drill a 10" diameter hole.
3. Using the sledge hammer and chisel, break up the concrete within the area that you cut and remove the pieces.
4. After you have removed the portion of the deck, undercut the sides as shown in the top diagram to the left. Remove enough material until the hole is 10" deep as shown.
5. Set the anchor system in place making sure that the front edge of the anchor is no more than 23 inches away from the pools edge, and that the KNOB is towards the pool as shown.
6. Using the string line or a straight edge, make sure the QUICKSET® DUAL-WEDGE ANCHOR is level and plumb with the FINISHED deck surface.
7. Bond/ground the anchor system using the grounding lug on the anchor plate according to your local code requirements.
8. Stow the knob inside the anchor and put the cover on it.
9. Pour your concrete (minimum 3000psi) and finish the pool deck surface.

## **QUICKSET® DUAL-WEDGE ANCHOR INSTALLATION / NEW CONSTRUCTION:**

For most applications the QUICKSET® DUAL-WEDGE ANCHOR will be installed in a newly poured concrete deck. Regardless of how the remainder of the deck is constructed, the QUICKSET® DUAL-WEDGE ANCHOR will need to be installed in a concrete section that fulfills the same requirements as the SAW-CUT installation (see previous page). The figure below shows the minimum requirements for the concrete; which are as follows;

- THE CONCRETE (PAD) NEEDS TO BE 48" X 48" X 8" MINIMUM
- THE QUICKSET® DUAL-WEDGE ANCHOR CAN BE SETBACK UP TO 23" FROM THE WALL
- THE CONCRETE SHOULD BE REINFORCED WITH #4 REBAR ON 10" CENTERS (IN BOTH DIRECTIONS – FORMING A GRID). MINIMUM 3000PSI CONCRETE
- THE ANCHOR KNOB MUST BE TOWARDS THE POOL WALL

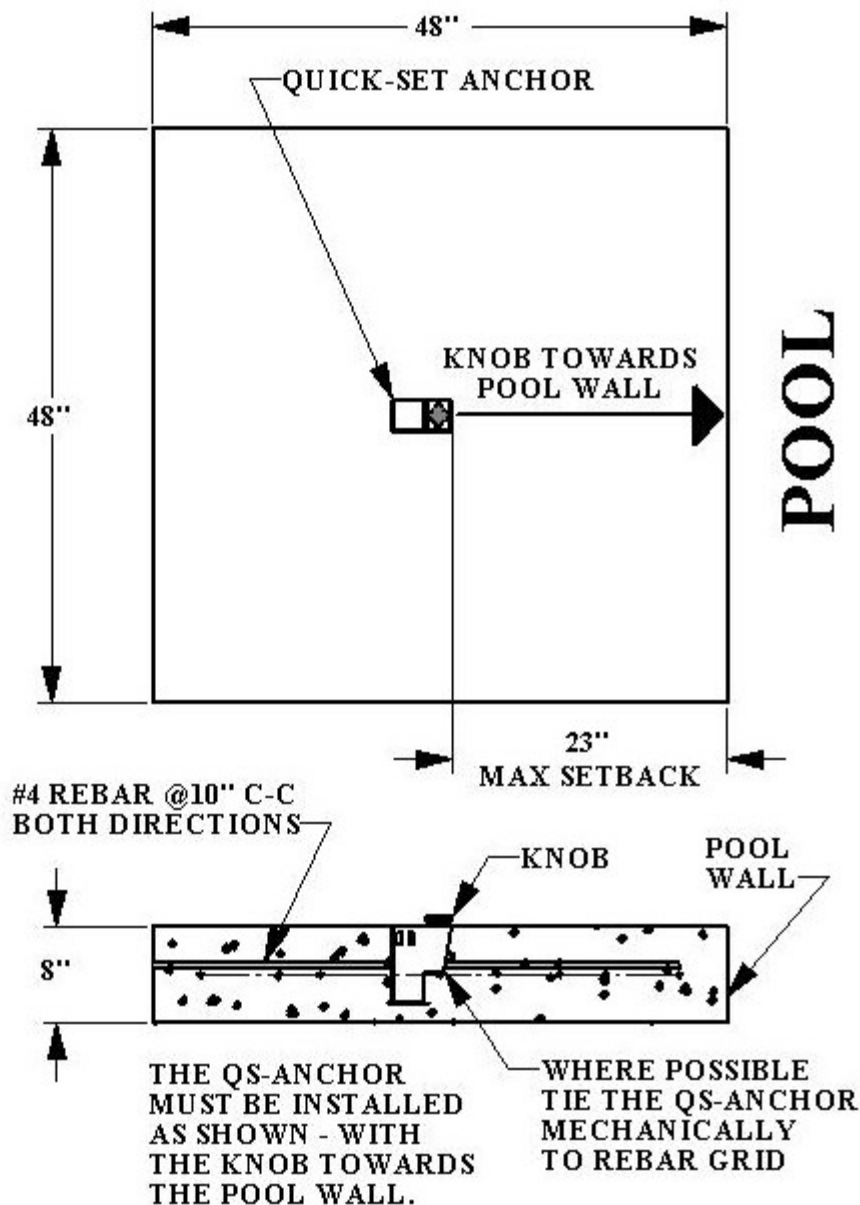

## AQUATRAM™ - ASSEMBLY INSTRUCTIONS

1. Attach Seat belt to the seat as shown.
2. Install the AquaTRAM Lift in the QUICKSET® DUAL-WEDGE ANCHOR; orient the lift as shown below and then slide the post into the anchor. When the lift is flush with the deck tighten the knob to lock in place. During use, periodically check to ensure that the knob remains tight.
3. Before installing the 24V battery, place it on the wall charger and let it charge for 24 hours (see Page 10). Make sure the orange "charge" light illuminates when the battery is being charged.
4. Remove the fully-charged battery from the charger and install it on top of the Control Box. The battery will line up square with the control box, and will 'click' when it locks in place properly. The lift will only operate when the battery is mounted properly.

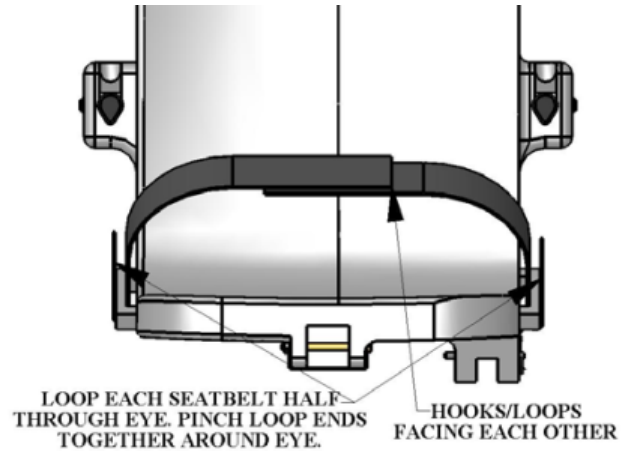

**WHEN NOT IN USE PLACE THE BATTERY ON THE CHARGER. DO NOT LEAVE THE BATTERY ON THE LIFT, OR OUTDOORS!**

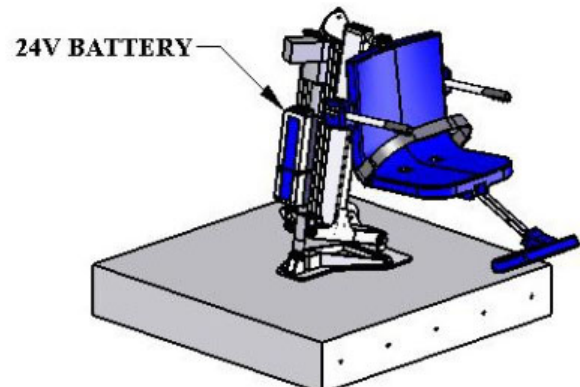
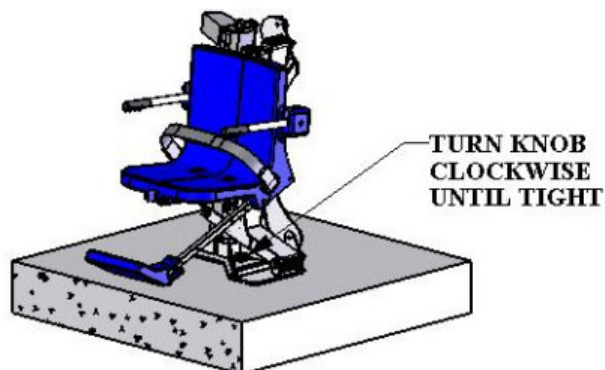
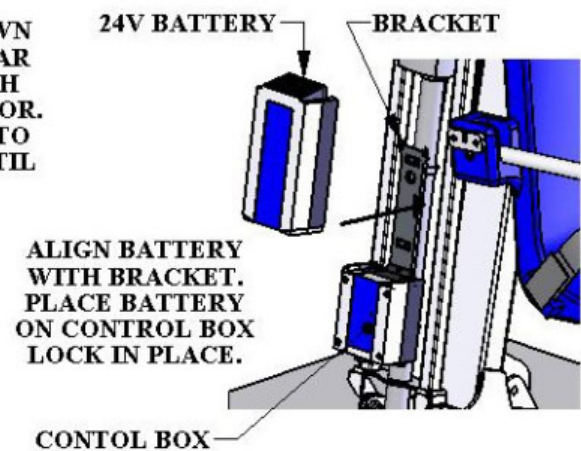
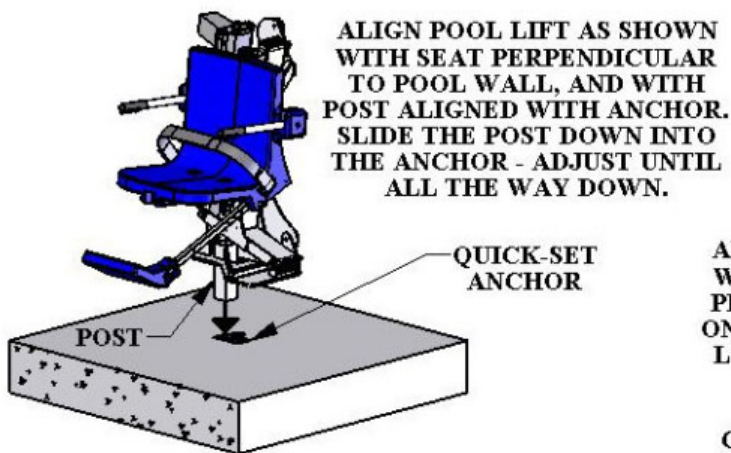



## 24V BATTERY SYSTEM OPERATING AND INSTALLATION INSTRUCTIONS



24V SEALED BATTERY  
(P/N 11211)



WALL MOUNT CHARGER  
(P/N 11277)



HAND CONTROL  
(P/N 11270)  
& CONTROL BOX  
(P/N 11271)

The AquaTRAM™ Lift comes with a 24v sealed rechargeable battery, wall mount charging unit (with mounting bracket), control box, and a waterproof handheld controller. The control box is mounted to the AquaTRAM™ Lift and has a plug-in socket for both the actuator and the handheld controller. The battery mounts directly above the control box with a quick-release clip.

To operate the AquaTRAM Lift, plug in the handheld controller to the control box and push the corresponding button to either lower or raise the unit. The lift should be able to complete approximately 10-20 full cycles before the low battery indicator tone will sound. The low battery tone indicates that there is approximately 20% battery life remaining. At this point, **DO NOT ATTEMPT TO OPERATE THE LIFT**, remove the battery from the unit and recharge on the wall mounted charging unit.

To recharge the battery, simply grip the top of the battery and depress the clip on the back of the battery. This will unclip the battery from the control box bracket and the battery can then be clipped into the wall mount charger. When the **charger** is plugged in the green **ON** light will illuminate. When the **battery** is correctly mounted to the charger, the orange **CHARGE** light will illuminate. When the battery is fully charged, the **CHARGE** light will **GO OFF** and the battery is ready for use.

**WHEN THE BATTERY IS NOT BEING USED IT SHOULD BE STORED ON THE CHARGER AND NEVER ON THE LIFT. DO NOT LEAVE THE BATTERY ON THE LIFT WHEN THE LIFT IS NOT IN USE.**

## BATTERY MAINTENANCE

1. **RECHARGE THE BATTERY AS OFTEN AS POSSIBLE.** The battery power unit is a sealed lead acid battery pack. Frequent recharges will prolong the battery life and maintain a high cold amperage capacity. **THE BATTERY CAN BE STORED ON THE CHARGER WHEN NOT IN USE.**
2. Do NOT expose the battery to freezing temperatures.
3. Do NOT expose the battery to prolonged periods of extreme heat or severe cold temperatures.
4. Do NOT expose the battery to long periods of direct sunlight. Heat will shorten your battery life. Optimum operating temperature is below 20 degrees Celsius (68 degrees F.)
5. Never drop or bump the battery pack. This may result in loose or damaged internal connections, and may bend the battery terminals.
6. Keep battery terminals clean and free from dirt and corrosion to ensure good contact. The terminals may be cleaned using Scotch Brite or any similar product. Clean off any corrosion or discoloration on the very top surfaces of the battery contacts and then apply dielectric grease (supplied with lift) as shown in the figure below.

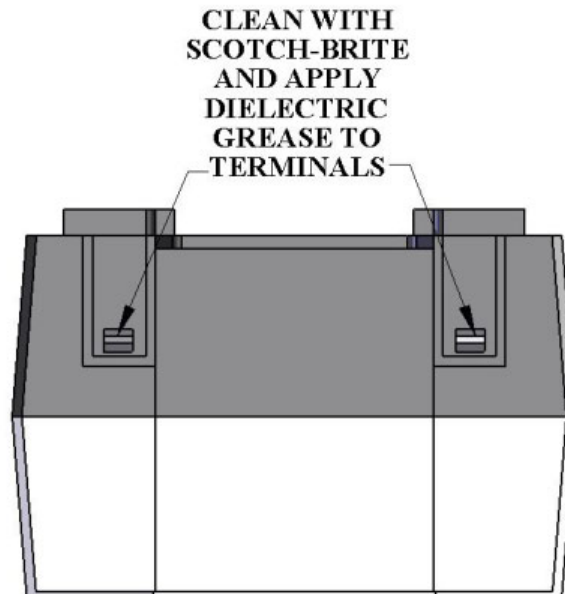

### **USING THE “EMERGENCY BUTTON” on the AquaTRAM Lift Control Box**

On the front side of the control box is a small recessed button marked “emergency”. Take a pen or pencil or other pointed object and depress the “emergency” button. This will bypass the remote control and send a signal directly to the actuator to raise the seat out of the pool and back to the deck or up position.

**NOTE: This function will only work if there is sufficient power in the battery, the battery is properly attached to the control box, and the control box must be operating properly.**



## **AQUATRAM™ Lift OPERATING INSTRUCTIONS:**

**WARNING! MAKE SURE THE BATTERY IS FULLY CHARGED BEFORE USING. NEVER OPERATE THE LIFT WITH THE ARMRESTS FLIPPED UP.**

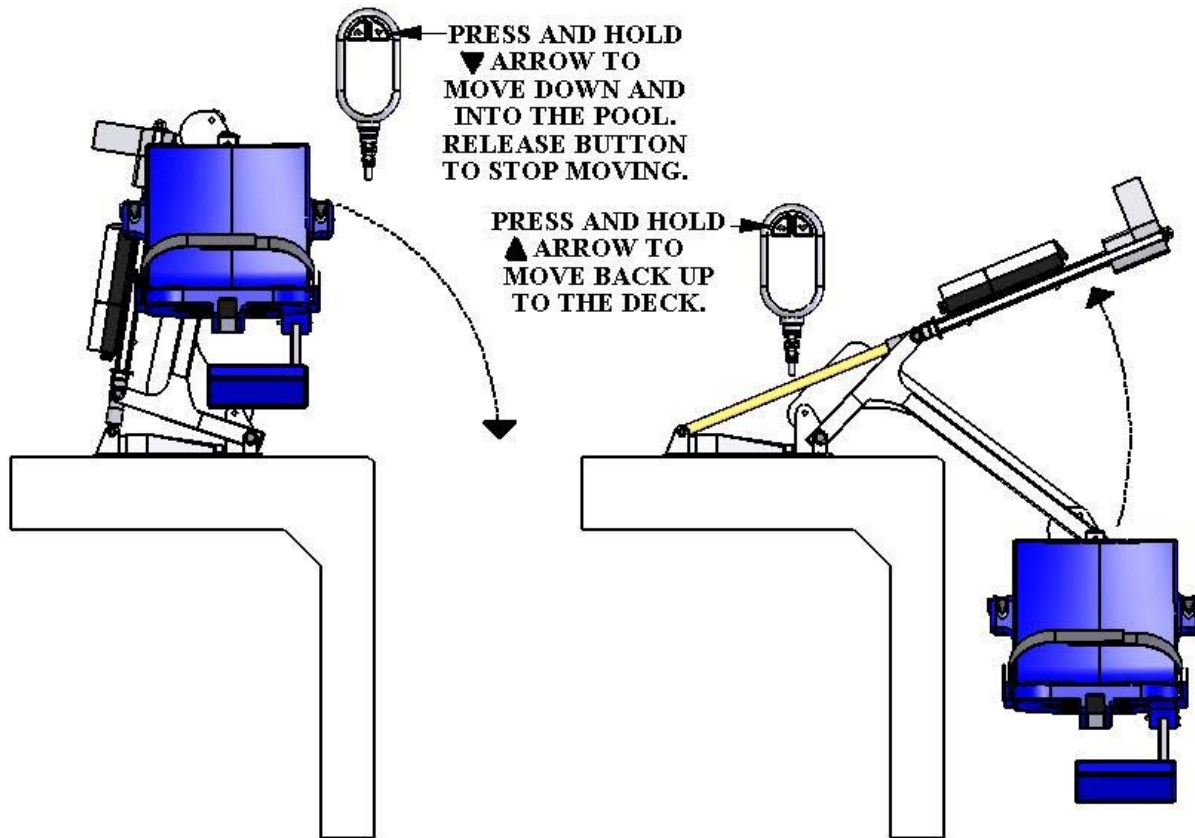

Always FASTEN THE SEATBELT before using the AquaTRAM lift. The seatbelt is adjustable. Adjust the footrest to a comfortable height. Find the HANDSET, which will be used to operate the lift.

**TO MOVE DOWN INTO THE POOL:** Press and hold the “DOWN” ▼ button. The lift will begin to move sideways and down towards the water. If you release the button at any time the lift will stop moving. To continue moving press and hold the ▼ button again. The lift will stop moving when the button is released, or when it reaches the end of its travel. THE BUTTON MUST BE HELD DOWN OR THE LIFT WILL STOP.

**TO MOVE BACK UP TO THE DECK:** Press and hold the “UP” ▲ button. The lift will begin to rise up out of the pool, and then will move sideways towards the deck. Again, if you want to stop moving simply release the button. The lift will stop either when the button is released or when it has reached the fully upright position, back on the deck.

**IF THE LIFT STOPS MOVING:** Make sure the button is held down. If the lift still doesn't move use the “EMERGENCY UP” button to move back to the deck (SEE PAGE 15). This will only work if the battery is sufficiently charged.

## **SAFETY & MAINTENANCE INSTRUCTIONS**

### **DO NOT PLAY ON OR AROUND THIS LIFT**

1. Check the AquaTRAM™ Series Pool Lifts before each use to assure there are no worn parts and that all hardware is properly tightened. If there are any worn parts, replace them BEFORE using the AquaTRAM™ Series Pool Lifts. You can call our customer service at 1-888-687-3552 to order any parts.
2. Pentair Water Commercial Pool and Aquatics lifts shall be grounded per local codes.
3. At least ONCE A WEEK, the AquaTRAM™ Series Pool Lifts must be cleaned with fresh water. Do not spray the AquaTRAM™ Series Pool Lifts 24v battery unit directly with any pressure. Wipe all surfaces clean with a damp, non-abrasive cloth. When cleaning the AquaTRAM™ Series Pool Lifts, use non-abrasive soap and water. Avoid harsh chemicals and disinfectants.
4. Always read the label instructions on any cleaner carefully before applying it to a surface.
5. The WARNING & INTENDED USE labels on the AquaTRAM™ Series Pool Lifts must be maintained in readable fashion. If they become unreadable or faded, please replace the label immediately. Replacement labels are available from Pentair Water Commercial Pool and Aquatics. 1-800-831-7133.

### **CARE OF YOUR LIFT**

Routine cleaning is an absolute necessity to ensure the integrity of the lift. Note that the AquaTRAM™ Lift should not be stored in a pump room or in a storage room where pool chemicals are kept. Storing the lift near pool chemicals may cause rusting and other damage to occur. Your stainless steel lift is powder coated to protect the stainless steel from rusting. Most rusting will occur at weld points, crevices, under gaskets, rivets or bolt heads.

The choice of a proper cleaning product is up to the consumer and there are many to choose from. Depending on the type of cleaning and the degree of contamination (rusting), some products are better than others. For routine cleaning the products most recommended are gentle soaps or detergents or dilute mixtures of ammonia. For stubborn spots and stains try using soft scrub with some brisk rubbing.

### **DO NOT USE POOL WATER TO CLEAN USE ONLY FRESH WATER**

If the lift is used **DAILY** make sure to wash the lift at the end of the day. Wash the lift off using a mild soap and a soft cloth. Make sure to pay special attention to weld points and crevices. Do not use a bristled brush or steel wool to clean the lift. Check that the lift is working properly and then place the battery on the charger. It is recommended that the battery be charged after every day of use.

If the lift is used **WEEKLY** follow the same steps as above. Also be sure to check all of the contact points (terminals) for damage or corrosion. If you notice corrosion gently clean the terminals. To clean corrosion from the terminals use a q-tip and some rubbing alcohol. If the corrosion is particularly stubborn try using a 3M scotch brite pad, but be careful not to damage the terminals. Apply dielectric grease to the terminals after cleaning them. This will help to prevent further corrosion. Do not leave the battery on the lift. Always store the battery on the charger whenever the lift is not being used.

If the lift is used **MONTHLY** follow the same steps as above. Also check the nuts and bolts to make sure they are securely fastened (this is always a good idea, no matter how often or infrequently the lift is used). Also make sure to store the battery on the charger and not on the lift. Leaving the battery on the lift for extended periods will significantly shorten the battery's lifespan.

If the lift is being **STORED** for an extended period of time follow all of the steps above. Check for rusting at all crevice and weld points. If you notice rusting spray some WD-40 on the affected area and take a 3M scotch brite pad and rub briskly. Afterwards be sure to wash and rinse the lift again with soap and water. When storing the lift make sure it is in a dry area and covered. **DO NOT STORE** in or around pool chemicals.

**BEFORE USING THE LIFT CHECK ALL NUTS AND BOLTS AND MAKE SURE THEY'RE TIGHT. ALSO INSPECT THE LIFT FOR RUST OR OTHER DAMAGE. DO NOT USE THE LIFT IF IT IS DAMAGED, IF THERE IS EXCESSIVE CORROSION (RUST), OR IF THERE IS MISSING OR LOOSE HARDWARE.**

## TROUBLESHOOTING GUIDE

Before troubleshooting make sure the battery is fully charged.

**If the lift doesn't move when the handset button is pressed:**

When you can't get the lift to move check the following things:

1. Make sure the battery is fully charged:
  - A. Before charging the battery first make sure the **green** light on the front of the charger is illuminated (this means that the charger is on). Then check to make sure the silver contact points on the battery and charger are not damaged or corroded, and that they are clean. Then place the battery on the charger and look for the **orange** charge light to illuminate on the front of the charger. When the orange light goes off the battery is fully charged.

The top **green light** will always be illuminated indicating that it has power. When charging the battery the bottom **orange light** will illuminate, until fully charged.



- B. When the battery is correctly installed on the charger or control box you should hear a "click" indicating the battery is properly seated on the unit. Also note that when the battery is properly seated there should not be any gaps between the battery and the control box/charger.



**Not attached properly.** Note the white bracket is in front of silver clip, which will not allow for an electrical connection.



**Properly Attached.** Note that the white bracket is behind the silver clip. Not allowing movement.

**If the battery is fully charged and the lift is not moving then:**

2. Check all cords:
  - A. Check that the cords are properly plugged in. Start by unplugging the remote and the actuator cord from the control box. Once these cords are removed check the ends for corrosion or damage. Plug the remote cord back in by lining up the raised tab on the plug to the grooved line on the control box outlet. Note that these cords require some force to plug them in fully. You will know they are correctly inserted when you hear a “popping sound”. The cords will be recessed into the outlet. If they are flush with the outside of the outlet they are not plugged in fully and the lift will not function. Make sure you do this for both cords.



**NOT inserted fully.**



**Fully inserted.**

**If you have checked all the cords and the lift still doesn't move:**

3. Check the contact points:
  - A. After you have fully charged the battery and checked the cords to make sure they are properly plugged in, check to make sure the contact points are not corroded or bent. If the contact points are corroded take some rubbing alcohol and a q-tip and clean off the points. After cleaning the contact points it is recommended to put some dielectric grease on the contact points (terminals) to help ensure good electrical contact and prevent corrosion. Then reinstall the battery on top of the control box. Make sure you hear a “click”, which indicates that the battery is correctly seated. The lift will not work if the battery is not seated correctly.

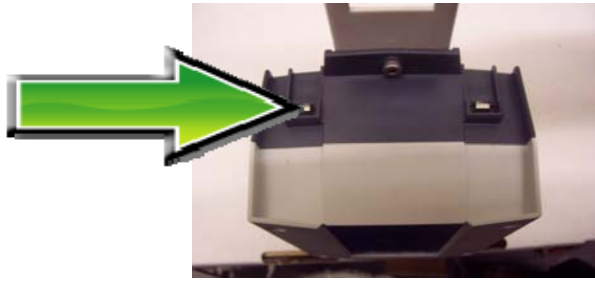

**Silver tabs are the contact (terminal) points.**

**If the lift stops moving over the water and is stuck:**

4. Then try pushing the emergency button:

A. If the lift gets stuck out over the water use a pen or pencil tip and stick it into the emergency button on the front of the control box to retract the lift. Note the lift will not retract if the battery is not fully charged or if the control box is not working. The emergency button only overrides the remote in case it has gone bad. If this does not retract the lift then chances are the remote is fine and you either have a problem with the battery, the control box, or the cords are damaged or not plugged in properly.

Use a pen or pencil tip to push in the small black circle located next to the word **emergency**, on the front of the control box.



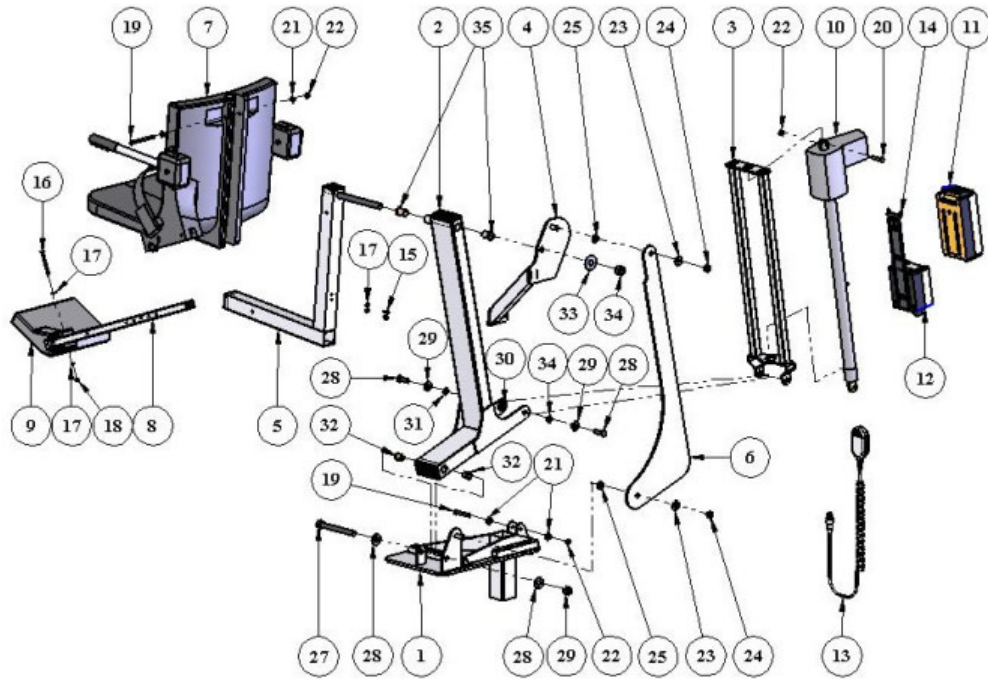

### AQUATRAM™: PARTS LIST

ITEM NO.	QTY	DESCRIPTION
1	1	AquaTram BASE ASSEMBLY
2	1	AquaTram FRAME ASSEMBLY
3	1	AquaTram ACTUATOR FRAME
4	1	AquaTram SEAT SUPPORT
5	1	AquaTram SEAT-ARM
6	1	AquaTram CONTROL ARM
7	1	AquaTram CHAIR ASSEMBLY
8	1	AquaTram FOOTREST TUBE
9	1	AquaTram FOOTREST
10	1	AquaTram LINEAR ACTUATOR
11	1	AquaTram 24v BATTERY
12	1	AquaTram CONTROL BOX
13	1	AquaTram 2-BUTTON HANDSET
14	1	AquaTram BATTERY/CB BRACKET
15	1	1/4"-20 X 1/2" HEX BOLT, SS
16	1	1/4"-20 X 3" HEX BOLT, SS
17	4	1/4" FLAT WASHER, SS
18	1	1/4"-20 NYLOCK NUT, SS
19	1	3/8" X 2-1/2" HEX BOLT, SS
20	2	3/8" X 1-3/4" HEX BOLT, SS
21	2	3/8" FLAT WASHER, SS
22	2	3/8"-16 NYLOCK NUT, SS
23	2	1/2" FLAT WASHER, SS
24	2	1/2"-13 NYLOCK NUT, SS
25	2	1/2" X 1/8" THRUST WASHER, BRONZE
26	2	1/2" X 1/4" FLANGE BEARING, BRONZE
27	1	5/8"-11 X 6" HEX BOLT, SS
28	2	5/8"-11 X 1-1/2" HEX BOLT, SS
29	4	5/8" FLAT WASHER, SS
30	2	5/8"-11 NYLOCK NUT, SS
31	2	5/8" X 1/8" THRUST WASHER, BRONZE
32	2	5/8" X 1" FLANGE BEARING, BRNZ
33	1	3/4" FLAT WASHER, SS
34	1	3/4"-10 NYLOCK NUT, SS
35	2	3/4" X 1" FLANGE BEARING, BRONZE



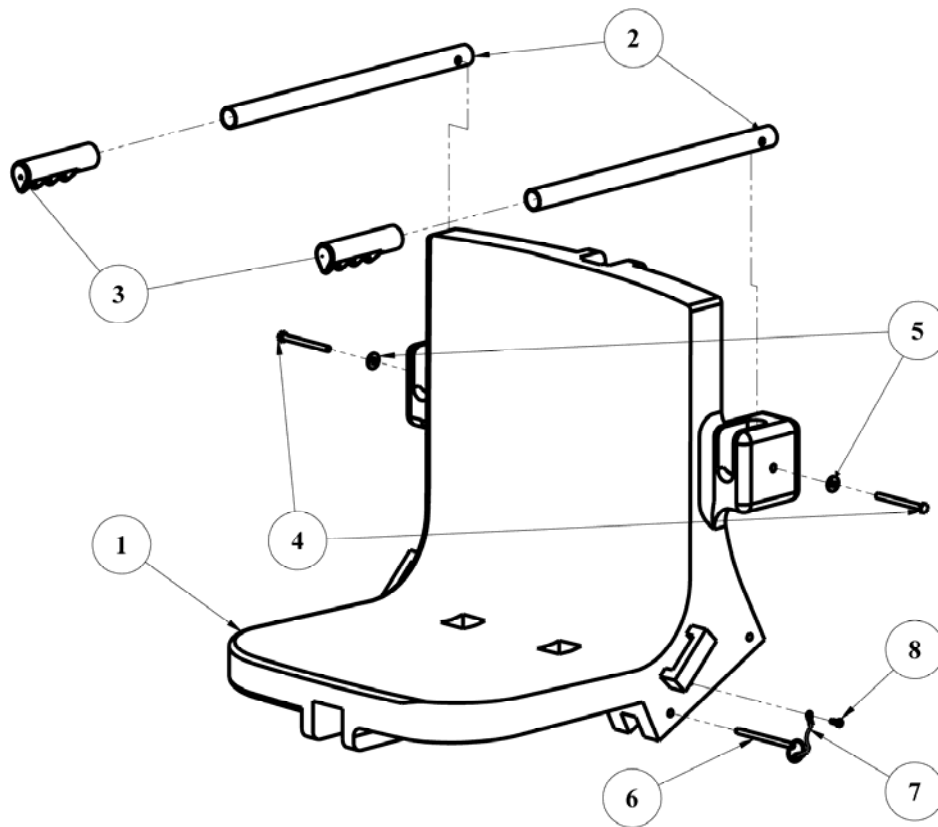

**SEAT ASSEMBLY: PARTS LIST**

ITEM #	QTY	DESCRIPTION
1	1	SEAT BODY
2	2	SEAT ARMREST TUBE
3	2	SEAT ARMREST HANDGRIP
4	2	1/4"-20 x 3" HEX BOLT, S.S.
5	2	1/4" FLAT WASHER, S.S.
6	1	1/4" QUICK RELEASE PIN, S.S.
7	1	LANYARD FOR QRP
8	1	SHEET METAL SCREW, S.S.

## Options for AquaTRAM™:

### Adjustable Head Rest (P/N 11205)

Includes:

- Padded head rest mounted to adjustable bracket with mounting hardware



### Adjustable Chest Strap (P/N 11206)

Includes:

- Adjustable hook and loop style chest strap and mounting hardware



### Pullout Leg Rest (P/N 11208)

Includes:

- Pullout leg rest (to be factory installed)

### Cycle Attachment (P/N 11207)

Includes:

- Pedal attachment and mounting hardware (cannot be used on lifts equipped with Pullout Leg Rest 11208)
- 90° up turned hand grips for better support

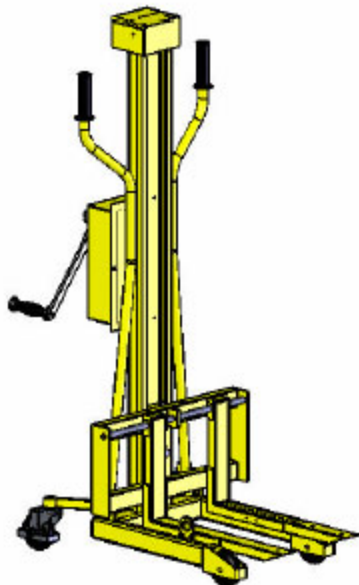

### Transport Cart (P/N 11203)

Includes:

- Heavy Duty lifting cart
- Lifting bar



### Protective Cover (P/N 11204)



A Division of Pentair Water Pool and Spa, Inc.

**AquaTram™ and AquaTram™ 360  
Swimming Pool Access Lift  
FIVE (5) YEAR LIMITED WARRANTY**

AquaTram™ and AquaTram™ 360 Lift (“Lift”) have a **Limited Lifetime Warranty** on the frames, not including the powder coat finish. Pentair Water Pool and Spa, Inc. (“Pentair”) also warrants to the original end user purchaser that these Lifts, when properly installed in accordance with assembly and installation instructions, and properly used and maintained, shall be free from defects in material and workmanship for a period of five (5) years from the date of original purchase, provided that Pentair receives prompt notice in writing of any claim and satisfactory proof thereof, with the following exceptions:

All electrical components, including the linear actuator shall have the following warranty coverage during the five (5) Year Limited Warranty periods:

- Year 1-2: 100% Coverage
- Year 3: 60% Coverage (Customer is responsible for 40% of replacement cost)
- Year 4: 50% Coverage (Customer is responsible for 50% of replacement cost)
- Year 5: 40% Coverage (Customer is responsible for 60% of replacement cost)

This warranty specifically excludes reimbursement for labor to remove, repair, replace or install the Lift or component part thereof and any return freight charges. These warranties do not cover any damages due to accident, misuse, abuse, negligence or failure to properly maintain any Lift or component part thereof, or normal wear and tear from day to day operations. In the event that any Lift or component part thereof are altered, repaired, or improperly installed or improperly used by anyone without the prior written approval by Pentair, all warranties are void. **IMPORTANT: AMOUNT OF WEIGHT PLACED ON LIFT SHALL NOT EXCEED THE RATED LIFT CAPACITY (400 POUNDS FOR The AquaTram™ Lift; 500 POUNDS for the AquaTram™ 360 Lift**

To initiate a warranty claim, the owner of an AquaTram™ Lift must provide the place of purchase, in writing, with a full description of the Lift, its serial number, the dates of purchase and installation, and the exact nature of the claim. Within thirty (30) days after receipt of a written warranty claim by Pentair, and barring any unforeseen delays, the place of purchase will be notified of Pentair’s decision regarding the claim.

If requested by Pentair, any Lift or component part thereof must be returned, freight prepaid, to Pentair’s designated factory location or duly appointed distributor for inspection and/or repair or replacement. Pentair will, at its option, refund the purchase price, or repair or replace the Lift or component part thereof, and deliver the repaired Lift or component part thereof or replacement to the buyer of the Lift, freight prepaid to the destination provided for in the original order. Lift or component part thereof returned to Pentair for which Pentair provides replacement under this limited warranty shall become the sole property of Pentair.

A new warranty period shall NOT be established for the repaired or replaced Lift or component part thereof. Such Lift or component part thereof shall remain under warranty only for the remainder of the original warranty period on the original Lift purchased.

This written limited warranty constitutes the final, complete and exclusive statement of warranty terms. No person or organization is authorized to make any other specific or implied warranties or representations on behalf of Pentair.

THE WARRANTIES SET FORTH HEREIN ARE IN LIEU OF ALL OTHER WARRANTIES, EXPRESSED OR IMPLIED, WHICH ARE HEREBY DISCLAIMED AND EXCLUDED, INCLUDING WITHOUT LIMITATION ANY WARRANTY OF MERCHANTABILITY OR FITNESS FOR A PARTICULAR PURPOSE OR USE.

THE SOLE AND EXCLUSIVE REMEDIES FOR BREACH OF ANY AND ALL WARRANTIES WITH RESPECT TO THE LIFT OR COMPONENT PART THEREOF SHALL BE LIMITED TO REPAIR OR REPLACEMENT AT PENTAIR’S DESIGNATED FACTORY LOCATION, OR DULY APPOINTED DISTRIBUTOR, OR SUCH OTHER LOCATION AT PENTAIR’S SOLE OPTION. IN NO EVENT SHALL PENTAIR’S LIABILITY EXCEED THE ENTIRE AMOUNT PAID TO PENTAIR BY THE ORIGINAL PURCHASER FOR THE LIFT OR COMPONENT PART THEREOF.

IN NO EVENT SHALL PENTAIR BE LIABLE FOR ANY INCIDENTAL, CONSEQUENTIAL, SPECIAL, INDIRECT, PUNITIVE OR EXEMPLARY DAMAGES OR LOST PROFITS FROM ANY BREACH OF THIS LIMITED WARRANTY OR OTHERWISE.

Pentair Water Commercial Pool and Aquatics™, A Division of Pentair Water Pool and Spa, Inc.

1620 Hawkins Ave., Sanford, NC 27330  
1351 Route 55, LaGrangeville, NY 12540

PENTAIR WATER POOL AND SPA, INC.  
1620 Hawkins Ave. Sanford, NC 27330 - 10951 W. Los Angeles Ave. Moorpark, CA  
93021  
- Phone 800-831- 7133  
- Fax 800-284-4151

P/N 11229 Rev A