

ANCHORS AND ACCESSORIES
MODEL - STEP TREAD 22"-15° 1.90" O.D.

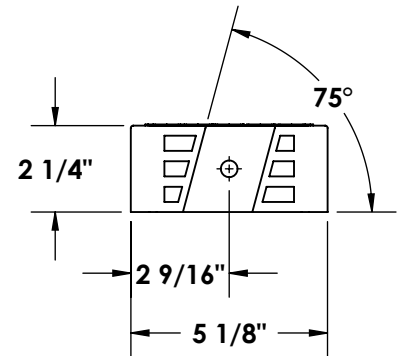

*Note: Specifications are nominal and are subject to change.
 Please contact Spectrum Aquatics for custom applications.

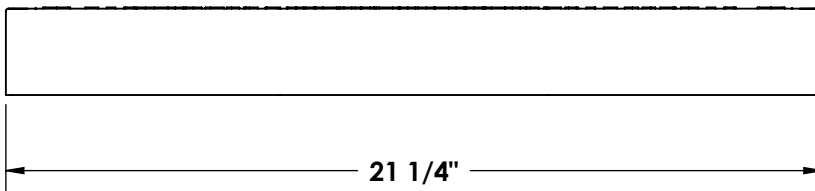
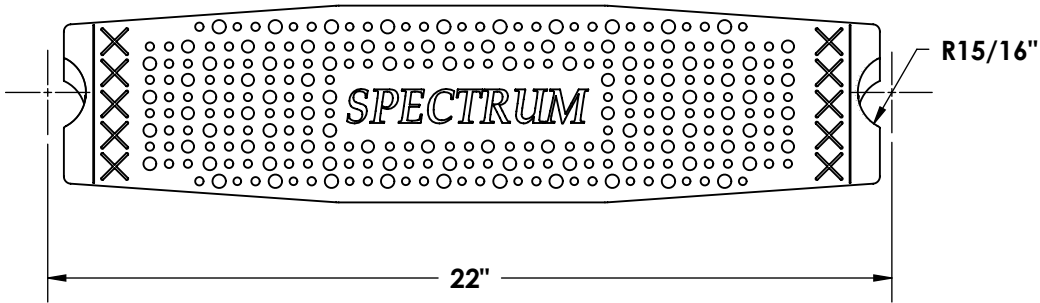
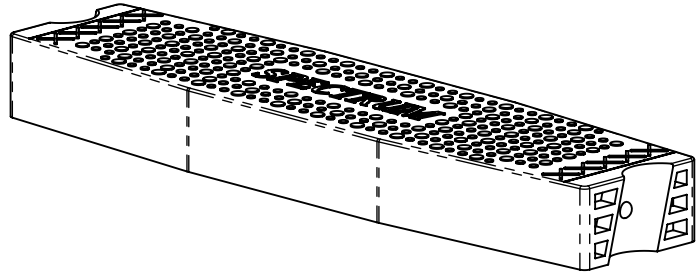

7100 Spectrum Lane
 Missoula, Montana 59808
 406.542.9781 * 800.791.8056
 Fax: 406.542.1158
 www.spectrumproducts.com

ENGINEERING DATA

PRODUCT:	STEP TREAD 22"-15° 1.90" O.D.
PRODUCT #:	24414-00
REVISION:	A
MATERIAL:	PE HIGH DENSITY